



VSRmini

OPERATING MANUAL



AC BALANCE CHARGER/DISCHARGER
for LiPo/LiFe/LiHV/Lilon/NiMH/NiCd/Pb Batteries

Please read and understand this entire operating manual before using.

OVERLANDER VSRmini CHARGER USER WARNINGS

**PLEASE FOLLOW THE FOLLOWING DIRECTIONS TO ENSURE
SAFE AND SUCCESSFUL USE OF THE OVERLANDER VSRmini
AC BALANCE CHARGER.**

WARNING : Read and familiarise yourself with the instruction manual before operating the charger, seek advice from other charger users or Overlander if you are unsure of any procedures.

This charger automatically balances Lithium batteries in charge/discharge and storage mode. When charging Lithium batteries, always ensure that the balance connector is connected **FIRST** in the sequence. This charger will not start a charge/discharge or storage charge if the balance lead is not connected. This charger will **NOT** charge batteries without a balance lead.

WARNING : This charger is not a domestic appliance, it should be only used and positioned in the correct environment.

Due to the power volatility of Lithium batteries it should be positioned on a fireproof base at least 1.5 metres from any flammable materials

WARNING :

- Never charge in a domestic setting
- Never leave the charger unattended
- Never exceed maximum battery charge rate
- Never charge a standard LiPo battery on LiHV setting
- Never charge non-approved or non EU compliant batteries
- Never charge in the wrong mode
- Never charge near flammable material
- Never charge near any items of value. Overlander or its retailers take no responsibility for 3rd party items that may be damaged by incorrect use.



Contents

1. Features	1
2. Exterior of the unit	2
3. Warnings and safety notes	3
4. Program flow chart	5
5. Parameter set up (User settings)	6
6. Lithium battery (LiPo/LiFe/LiHV/Lilon) programs	8
6.1 Charging	8
6.2 Balance mode	9
6.3 'FAST' charging	10
6.4 'STORAGE' mode	10
6.5 Discharging	11
6.6 Voltage balancing and monitoring during discharge	11
7. NiMH/NiCd battery programs	12
7.1 Charging	12
7.2 Discharging	12
7.3 'CYCLE' mode	13
8. Pb (lead acid) battery program	13
8.1 Charging Pb battery	13
8.2 Discharging Pb battery	14
9. Battery internal resistance testing system	14
10. Save Data Program	15
11. Load Data Program	16
12. Program information	16
13. Warning and error messages	17
14. Specifications	19
15. Warranty and service	19

1. Features

Optimised operating software

The VSRmini has an 'AUTO' function that sets the current automatically when charging or discharging, preventing the battery from over-charging, which could lead to a fire or explosion. These specifications can also be set by the user. The built in balance charge port makes it convenient for use with Lithium batteries. This charger also comes with XT60 to Deans conversion lead for Deans type batteries.

High-power and high-performance circuit

The max output is 80W. The max charge is 7A. The max discharge current is 1A. It can charge/discharge NiMH/NiCd battery with up to 15 cells, and Lithium batteries with 6 cells. The CPU operating program works under such power as the charger is fitted with a highly efficient cooling system.

Individual voltage balancer for Lithium batteries inside

The charger has a special internal function for Lithium battery voltage balancing. You do not require an additional balancer to balance the voltage when charging Lithium batteries (LiPo/LiFe/Lilon).

Balance individual cells

The charger also monitors and balances the individual cells of a Lithium battery pack during the charging/discharging process. If the voltage of any cell varies abnormally, the process will be stopped automatically and an error message will appear on the screen.

Accept various types of Lithium battery

This charger can be used with a wide range of batteries with different chemistries (LiPo, LiHV, LiFe, Lilon, NiMH, NiCd and Pb). Choose the corresponding program, setting the parameters on the base of the battery type and specifications, before you start to charge/discharge.

Lithium battery 'Fast' and 'Storage' mode

The "Fast" charge reduces the charging time of Lithium batteries. The "Storage" mode controls the nominal voltage of the battery to make it suitable for long-term storage.

NiMH/NiCd cyclic charging/discharging

With this charger you can perform 1-4 cycles of charge>discharge or discharge>charge continually for battery refreshing and balancing.

Data store/load

This charger can store a maximum of 5 different batteries data. These settings can then be called out at any time and the process can be executed without having to reselect all of the correct settings.

Maximum safety

- **Delta-peak Sensitivity:** when the battery voltage of NiMH/NiCd batteries reaches the highest point and begins to drop, the charging process will automatically stop.
- **Capacity Limit:** the charging process will terminate automatically when the maximum capacity value that is set is reached.
- **Temperature Limit:** the temperature of the battery will rise during the charging process due to internal chemical reactions. In order to prevent overheating the charging process will forcibly end if the temperature limit that is set is reached. This function is only available by connecting an optional temperature probe, which is not included in the package. Available from Overlander (SKU: 2598).
- **Charge Time Limit:** charging will stop when charge time limit set is reached to avoid any possible over-charging/over-discharging.
- **Input Current Check:** to prevent the battery from being damaged by the input current, the charger monitors the voltage and ends the process automatically when the voltage drops below the lowest limit.
- **Automatic cooling fan:** the automatic electric cooling fan controls the internal temperature of the charger to prevent over-heating.

2. Exterior of the unit

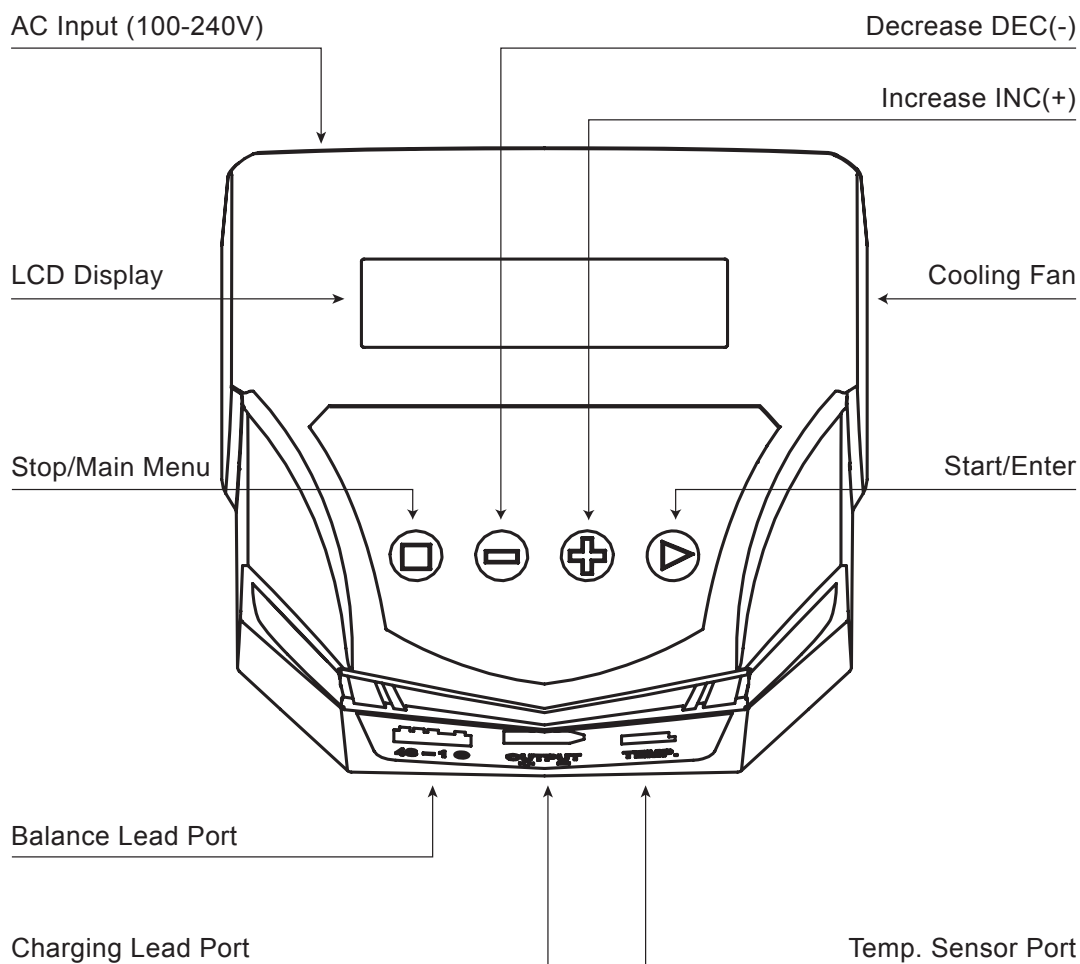

3. Warnings and Safety notes

IMPORTANT! Please follow these instructions for maximum safety, otherwise the charger and/or battery could be badly damaged and may lead to fire, explosion, injury or property loss.

- Never leave the charger unattended when it is connected to its power supply.
- If any malfunction is observed, terminate the process immediately and refer to the manual.
- Keep the charger away from dust, damp, humidity, rain, heat, direct sunshine and vibration.
- The circuit of the unit is designed to be powered by 100-240V AC only.

NiCd / NiMH	Voltage level: 1.2V/cell Recommended fast charge current: 1C~2C depends on the performance of cell discharge voltage cut off level 0.85V/cell (NiCd), 1.0V/cell (NiMH)
Lilon	Voltage level:3.6V/cell Max. charge voltage: 4.1V/cell Recommended fast charge current: 1C or less Min. discharge voltage cut off level: 2.5V/cell or higher
LiPo	Voltage level: 3.7V/cell Max. charge voltage: 4.2V/cell Recommended fast charge current: 1C or less Min. discharge voltage cut off level: 3.0V/cell or higher
LiHV	Voltage level: 3.8V/cell Max. charge voltage: 4.3V / 4.35V / 4.4V/cell Recommended fast charge current: 1C or less Min. discharge voltage cut off level: 3.0V/cell Ensure maximum charge voltage is set. This would usually be 4.35V but please check instructions with the LiHV battery. Never charge standard LiPo battery on LiHV setting.
LiFe	Voltage level:3.3V/cell Max. charge voltage:3.6V/cell Recommended fast charge current: 4C or less Discharge voltage cut off level:2.0V/cell or higher
Pb	Voltage level:2.0V/cell (Lead-acid) Max. charge voltage:2.46V/cell Recommended fast charge current:0.4C or less Min. discharge voltage cut off level:1.50V/cell or higher

- Do not place the charger on flammable or conductive surfaces when charging/discharging. Never use the charger on car seats, carpets or similar surfaces. Do not operate near items of value or anything with the potential to catch fire or explode.
- Ensure the unit remains well ventilated by making sure that all ventilation holes are unblocked and uncovered.
- Set the parameters correctly, otherwise the battery could be severely damaged. Lithium batteries especially can cause a fire or explosion when over-charged. Always check that the selected chemistry is correct. Never charge standard LiPo batteries on LiHV setting.
- To avoid short-circuits between the wires, always connect the charge cable to the unit first and then to the battery. Reverse the sequence when disconnecting.
- **Always check the capacity and voltage of a Lithium battery pack before starting any process.** It may be a mixture of parallel and series connections. In parallel, individual cell capacity multiplied by the cell count is the pack capacity, but the voltage remains the same. It is important to enter the correct parameters in order to prevent the risk of fire/explosions.
- When setting the discharge parameter, it must be according to the residual capacity of the pack to lower the voltage of the battery. To avoid over-discharging, please set the nominal discharge correctly. The voltage of Lithium batteries must not be discharged lower than the minimum voltage because this can lead to a rapid loss of capacity or a total failure. **Generally there is no need to discharge a Lithium battery.**
- Some batteries have a 'memory', in that if the capacity is only partially used the battery will 'remember' to just use the same amount in the future:
 - NiMH and NiCd batteries do have a memory function, but usually run complete cycles. This means they are fully charged and then completely used.
 - Lithium batteries prefer a partial rather than full discharge. Frequent full discharge should be avoided if possible. Instead you should charge the battery more often or keep the nominal voltage.
- This charger is not a domestic appliance. It should be used and positioned in the correct environment and should not be used in a domestic setting. Due to the power and volatility of Lithium batteries the charger and battery should be placed on a fireproof base at least 1.5 metres from any flammable materials. Overlander or its retailers accept no liability for losses to 3rd party items caused by failure to follow these instructions.
- By purchasing this product the user assumes all risks associated with its use. If you do not agree with this clause then please return the item immediately before use.
- Failure to comply with these instructions will result in all warranties being deemed void.

4. Program flow chart

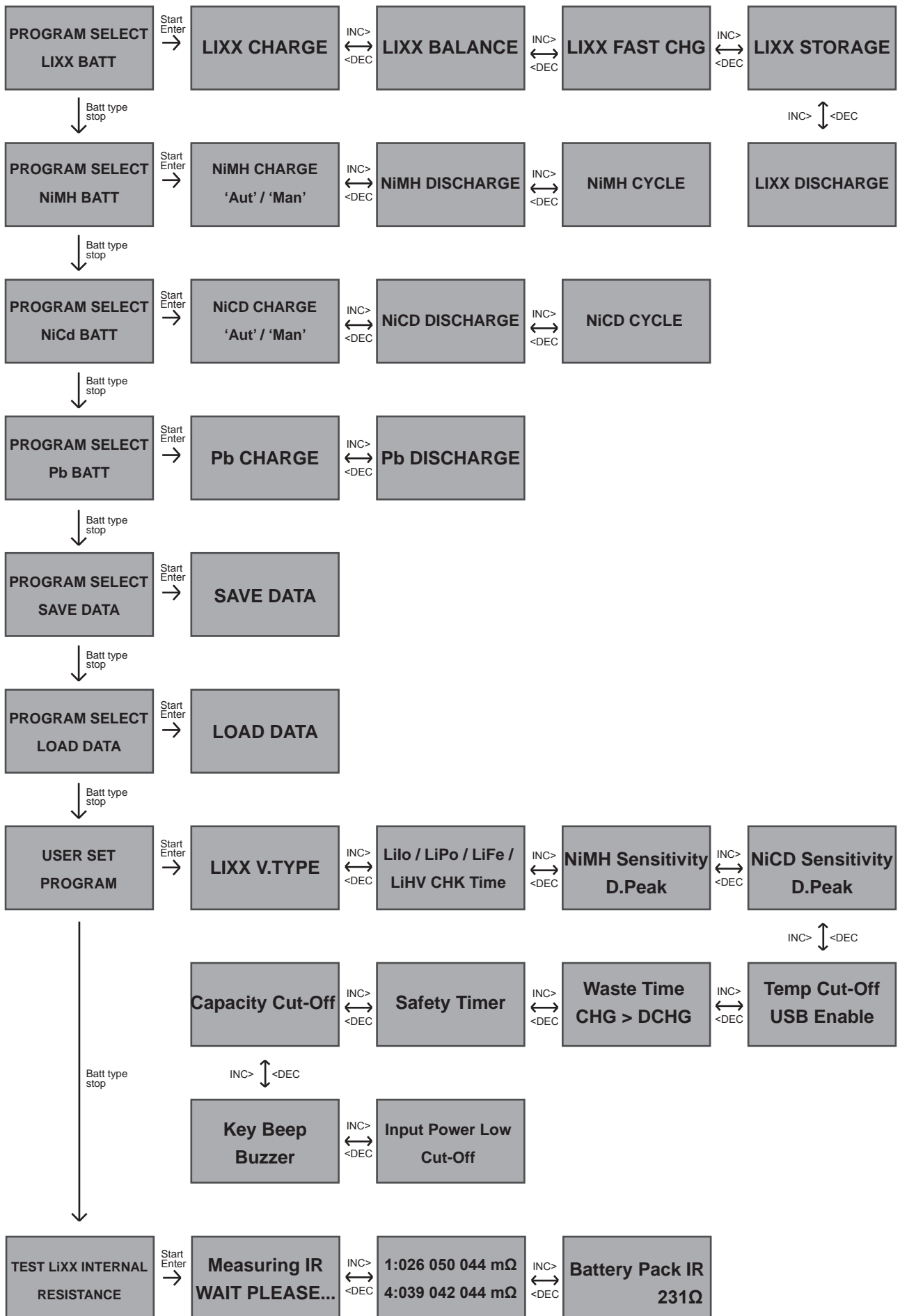

5. Parameter set-up (User settings)

The charger will automatically be operated with the default user settings when it is connected to a 12V battery for the first time. The screen displays the following information in sequence and the user can change the value of the parameters on each screen. If you want to alter the parameter value in the program, press **Start/Enter** to make it blink then change the value with **INC** or **DEC**. The value will then be stored by pressing **Start/Enter**.

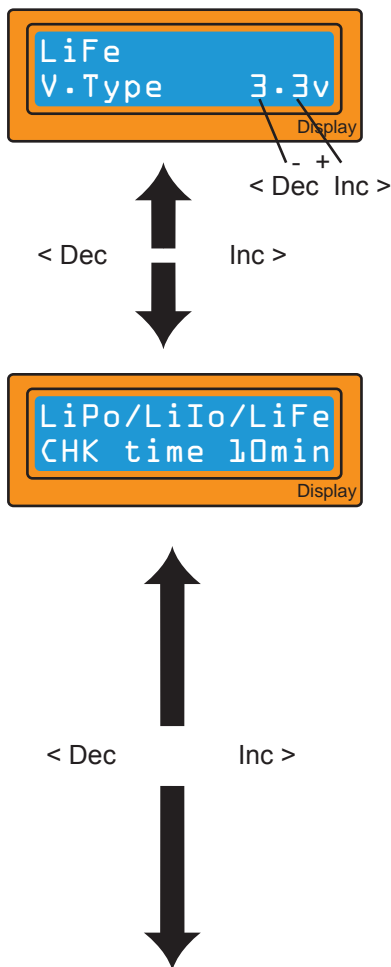

The screen displays the nominal voltage of the Lithium battery. There are four kinds of Lithium battery; **LiFe (3.3V)**, **Lilon (3.6V)**, **LiPo (3.7V)** or **LiHV (3.8V)**. It is very important that you check the battery carefully to ensure it is set up correctly. If the incorrect values are selected the battery could ignite or explode during the charging process.

The charger will recognise the cell count of the battery automatically at the beginning of the charge or discharge process to reduce the chances of incorrect settings being selected by the user. However, a deeply discharged battery can be perceived incorrectly, so it is important to check that all of the information is correct. To prevent any errors, you can set the time term to verify the cell count detected by the processor. Normally 10 minutes is enough to perceive the cell count correctly. For a battery of a larger capacity, you may need to extend the time term. However, be careful not to set the time term for too long for a battery of a smaller capacity, as the charge or discharge process can be finished within the time term with the wrong cell count, which could then result in over-charging the battery.

If the processor recognises the cell count incorrectly at the beginning of the charge or discharge process, you may extend the time. Otherwise, it is recommended that you use the default value.

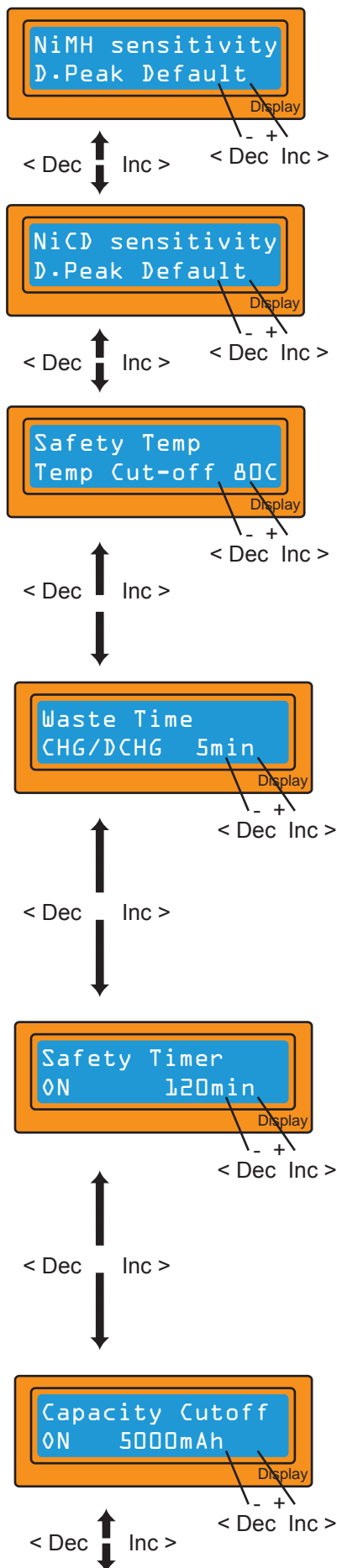

This shows the trigger voltage for automatic charge termination of NiMH and NiCd battery. The effective value ranges from 5 to 20mV per cell. If the trigger voltage is set higher, there is a danger of overcharging the battery; if it is set lower, there is a possibility of premature termination. Please refer to the technical specifications of the battery. **(NiCd default: 12mV, NiMH default: 7mV)**

The 3-pin port at the left side is a temperature port. You can use a temperature probe to contact the surface of a battery. You can set the maximum temperature at which the charger will allow the battery to reach during charging. Once a battery reaches this temperature during charge, the process will be terminated to protect the battery.

This shows a battery that is on a cyclic process of charge and discharge. These can often become warm after the charge or discharge period. This program can insert a time delay to occur after each charge and discharge process to allow the battery adequate time to cool down before being subjected to the next process. The value ranges from 1 to 60 minutes.

When you start a charge process, the integral safety timer automatically starts running at the same time. This is programmed to prevent overcharge if the battery proves to be faulty and the termination circuit cannot detect if the battery is full. The value for the safety timer should be generous enough to allow a full charge of the battery.

This program sets the maximum charge capacity that will be supplied to the battery during charge. If the delta-peak voltage is not detected, or if the safety timer is not working for any reason, this feature will automatically stop the process when the battery reaches the selected capacity value.

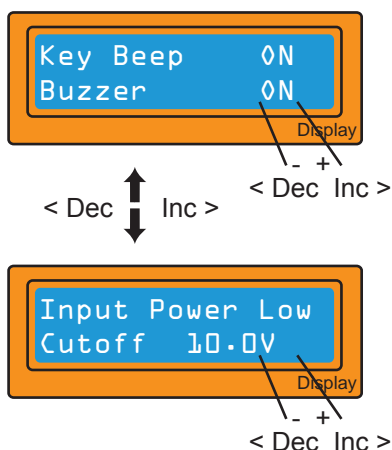

The beep sounds every time a button is pressed to confirm your action. Beeps or melodies may be sounded at various times during operation to alert the user of different mode changes. You can turn these sounds on and off.

This program monitors the input voltage to the battery. If the voltage drops below the value you set, the operation will be forcibly terminated to protect the battery.

6. Lithium Battery Programs (Lilon/LiPo/LiFe/LiHV)

These programs are only suitable for charging and discharging Lithium batteries with a nominal voltage of **3.3V (LiFe)**, **3.6V (Lilon)**, **3.7V (LiPo)** and **3.8V (LiHV)** per cell. These various battery types will all have different charge voltages (CV) and charge currents (CC). The charge current input varies according to the battery capacity and performance, so **it is very important that you select the correct battery type before starting any process.**

The final voltage of the charge process is also very important; it should be precisely matched with the correct voltage of the battery. Per cell these voltages are: **3.6V for LiFe**, **4.1V for Lilon** or **4.2V for LiPo**. The option for peak cell voltage of 4.4V for LiHV should only be used if the battery instructions specifically allow this, to prevent danger of overcharging. Otherwise select either **4.3V or 4.35V for LiHV**. The charge current and nominal voltage, as per the cell count set on the charge program, must always be correct for the battery being charged.

If you wish to alter the default parameter value in the program, press **Start/ Enter** to make the value blink then change the value with **INC** or **DEC**. The value will be stored by pressing **Start/Enter** once.

6.1 Charging Lithium Batteries

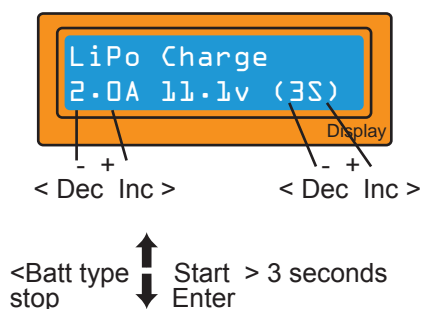

On this screen the top line displays the battery type and the second line shows the charge current and the voltage of the battery pack.

After selecting the correct current and voltage, hold **Start/Enter** down for 3 seconds to start the process.

(Charge current: 0.1~6.0A; Voltage: 2-4S)

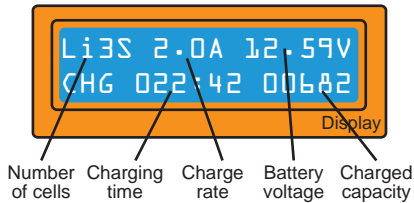
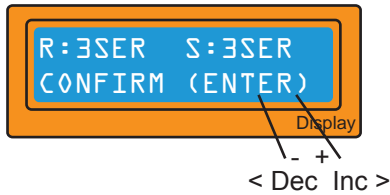

This shows the number of cells within the battery pack. 'R:' is the number of cells found by the charger, and 'S:' is the number of cells selected by the user on the previous screen. If both numbers are identical you can start charging by press **Start/Enter**. If not, press **Batt Type/Stop** to go back to previous screen to modify any incorrect information that may have been input by the user.

This screen shows the present position of the charging process. To stop charging press **Batt Type/Stop** once.

6.2 Charging Lithium batteries in 'BALANCE' mode

This mode is used to balance the individual cells of a Lithium battery. The pack being charged should be connected to the suitable balance port at the right side of the charger as well as to the output plug of the charger.

In this mode, the charging process will be different from the ordinary charging mode. The internal processor of the charger will monitor the voltages of each cell within the pack and control the charging current that is feeding to each cell to normalise the voltage.

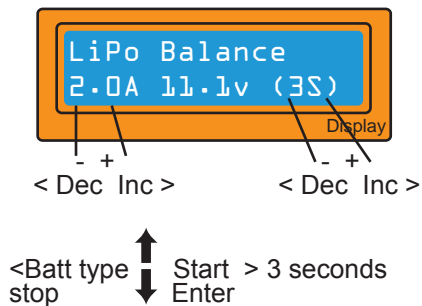

On this screen the first value on the second line is the charge current and the second value is the voltage of the battery pack.

After selecting the correct values for the current and voltage hold **Start/Enter** for 3 seconds to start the process.

(Charge current: 0.1~6.0A; Voltage: 2-4S)

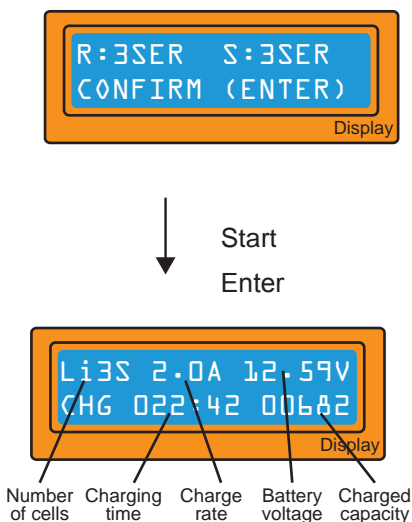

This shows the number of cells within the battery pack. 'R:' is the number of cells found by the charger, and 'S:' is the number of cells selected by the user on the previous screen. If both numbers are identical you can start charging by pressing **Start/Enter**. If not, press **Batt Type/Stop** to go back to previous screen to modify any incorrect information that may have been input by the user.

This screen shows the present position of the balance charging process. To stop charging press **Batt Type/Stop** key once.

6.3 'FAST' charging Lithium batteries

The charging current decreases as the process reaches its end, meaning that the charge process will slow down. To speed up the charging process, the 'FAST' charging program eliminates certain aspects of the cut-off voltage process. The charging capacity may be slightly less than normal but the process time will be reduced.

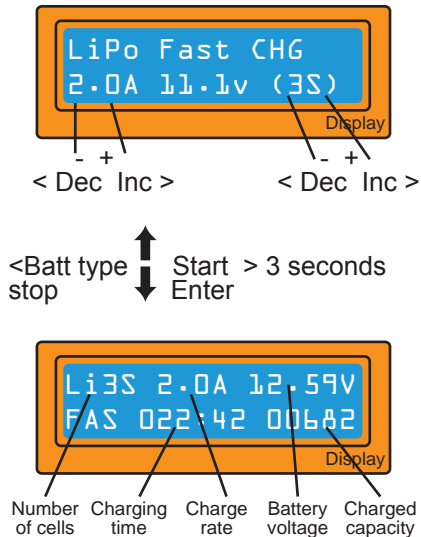

You can set up the charging current and the voltage of the battery pack which is being charged. Press **Start/Enter** to bring up the voltage confirmation screen. If the voltage and current parameters are correct, press **Start/Enter** again to start the charging process.

This screen shows the present position of the 'FAST' charging process. To stop charging press **Batt Type/Stop** once.

6.4 'STORAGE' control for Lithium batteries

This mode is for charging or discharging Lithium batteries that are going to be stored for any length of time. The program will charge/discharge the battery to the best voltage for storing, depending on the current voltage of the battery. Voltages per cell differ depending on the battery chemistry: **3.3V for LiFe**, **3.75V for Lilon**, **3.85V for LiPo**, and **3.85 for LiHV**. If the voltage of the battery in its current state is over the ideal voltage level for storage, the program will start to discharge.

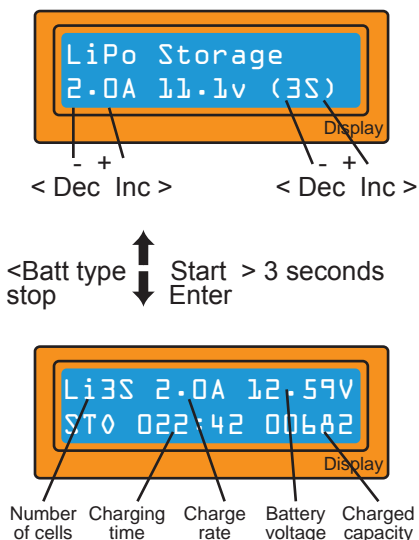

Here you can input the current and the voltage of the battery pack to be charged. The current will be used to either charge or discharge the battery in order for it to reach the ideal 'STORAGE' level voltage.

This screen shows the present position of the 'STORAGE' process. To stop charging press **Batt Type/Stop** once.

6.5 Discharging Lithium batteries

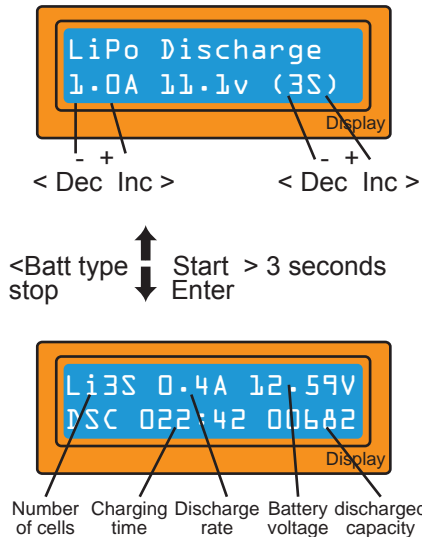

The discharge current (shown on the left side of the screen) should not exceed 1C and the final voltage on the right should not be under the voltage level that is recommended by the battery manufacturer to avoid deep discharging. To start the discharge process, hold **Start/ Enter** key for 3 seconds.

This screen shows the present position of the discharging process. To stop discharging press **Batt Type/Stop** once.

6.6 Voltage balancing and monitoring during discharge

The processor monitors the voltage of the individual cells of the Lithium battery pack during 'storage-mode' and 'discharge'. It tries to normalise the voltages of each cell so they are all equal. For this feature, the individual plug of the battery pack should be connected to the individual port of the charger.

If the voltage of one or more cells appears abnormal, the charger will automatically terminate the process and an error message will show on the screen. The occurrence of this indicates that the battery pack contains a damaged cell, or that the battery has not been connected to the charger correctly. To find out which cell within the pack is damaged, press **INC** while the error message is on the screen.



This screen will appear if the processor finds that the voltage of one of the cells in the Lithium battery pack is too low.



In this example, the 4th cell is faulty. In the case that the battery is not connected to the charger correctly, all of the values will show zero.

7. NiMH/NiCd battery programs

These programs are only for charging or discharging NiMH (Nickel-Metal-Hydride) or NiCd (Nickel-Cadmium) batteries. If you wish to alter the default parameter value in the program, press **Start/Enter** to make the value blink then change the value with **INC** or **DEC**. The value will be stored by pressing **Start/Enter** once.

7.1 Charging NiCd/NiMH batteries

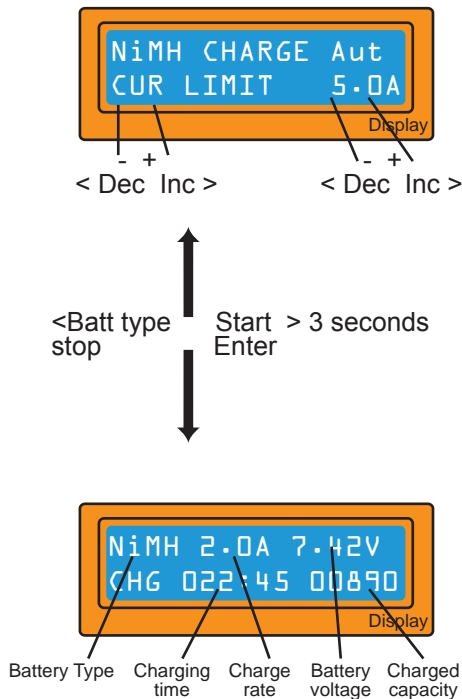

This program charges the battery using the charge current set by the user. In 'Aut' mode, you must set the charge current limit to prevent the charger feeding too much current into the battery, which could cause damage. In 'Man' mode, the battery will be charged with the charge current set by the user. You can change the mode by pressing **INC** and **DEC** button simultaneously when the current field is blinking.

This screen shows the present position of the charging process. To stop charging press **Batt Type/Stop** once.

7.2 Discharging NiCd/NiMH batteries

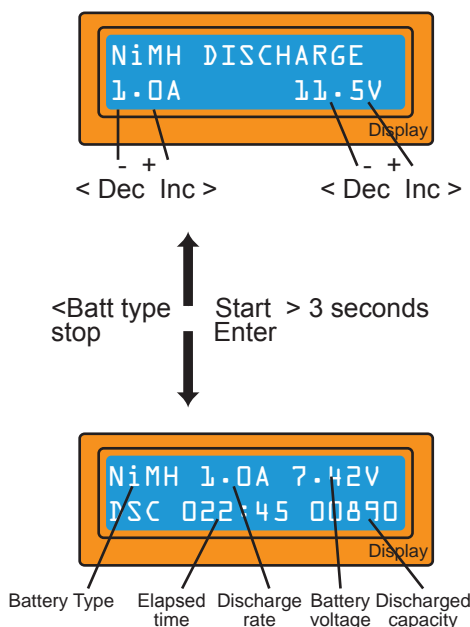

The discharge current is shown on the left and the voltage of the pack on the right. The discharge current ranges from 0.1A to 1.0A and the final voltage ranges from 0.1V to 25.0V). You can alter the parameters by pressing **Start/Enter**. Once the correct values have been input, press **Start/Enter** again to store the values. To start the process, hold **Start/Enter** for 3 seconds.

This screen shows the present position of the discharging process. To stop discharging press **Batt Type/Stop** once.

7.3 'CYCLE' mode for NiMH/NiCd batteries

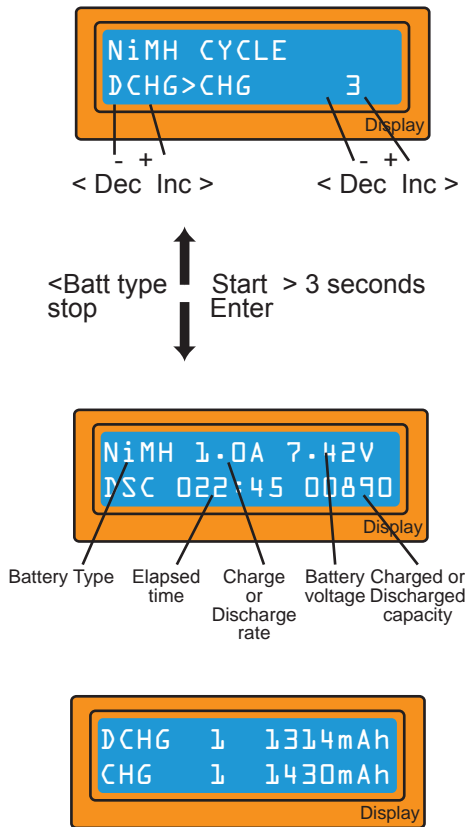

On this screen you can alter the cycle sequence on the left and the number of cycles on the right. The 'CYCLE' mode can be used for balancing, refreshing and 'breaking-in' the battery. A time delay will occur after each charge and discharge process to allow the battery adequate time to cool down before being subjected to the next process. This delay is set on the 'User Settings' menu.

This screen shows the present position of the charging/discharging process. To stop charging/discharging press **Batt Type/Stop** once.

At the end of the process, the screen will display what the battery capacity was after each cyclic process. Pressing **INC** or **DEC**, to scroll through the results of each cycle in order.

8. Pb (lead-sulphuric acid) battery programs

These programs are suitable for charging Pb (lead-sulphuric acid) batteries with a nominal voltage from 2V to 20V. Pb batteries deliver relatively lower current compared to their capacity, and similar restrictions come into play when charging. The optimal charge current of Pb batteries will be 1/10th of the capacity; they must not be charged rapidly. Always follow the instruction supplied by the manufacturer of battery.

If you wish to alter the default parameter value in the program, press **Start/Enter** to make the value blink then change the value with **INC** or **DEC**. The value will be stored by pressing **Start/Enter** once.

8.1 Charging Pb batteries

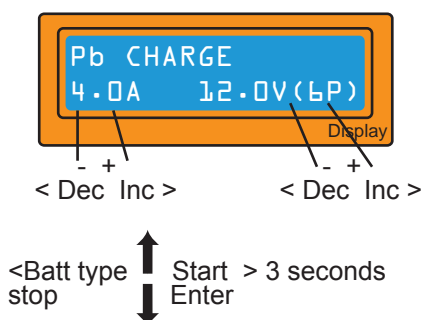

The charge current is shown on the left and the nominal voltage of the battery on the right. The charge current ranges from 0.1A to 6.0A and the voltage should be matched with the battery being charged. To start the charge process, hold **Start/Enter** for 3 seconds.

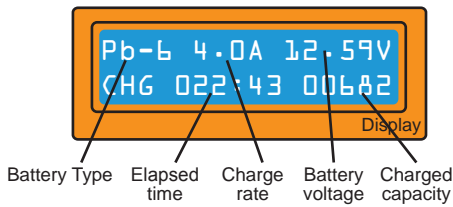

This screen shows the present position of the charging process. To stop charging press **Batt Type/Stop** once.

8.2 Discharging Pb battery

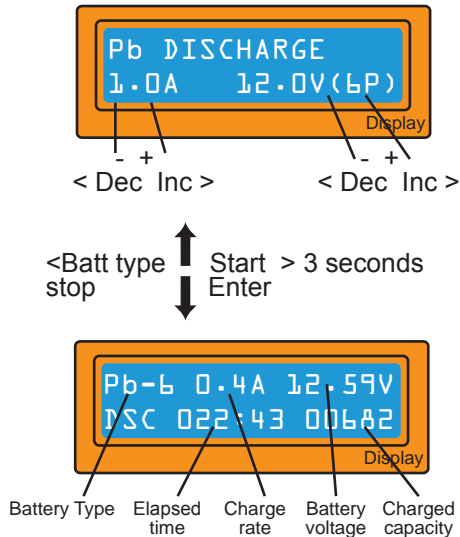

The discharge current is shown on the left and voltage of the battery pack on the right. The discharge current ranges from 0.1A to 1.0A. You can alter the parameters by pressing **Start/Enter**. Once the correct values have been input, press **Start/Enter** again to store the values. To start the discharging process, hold **Start/Enter** for 3 seconds.

This screen shows the present position of the discharging process. To stop discharging press **Batt Type/Stop** once.

9. Internal resistance testing system

Lithium battery internal resistance (IR) is an important measure of battery discharge, capacity and efficiency. We can discover the battery performance and the matching of each cell by getting the battery resistance value. The Lithium battery IR value tested by this charger is relative (not absolute). Battery packs are subject to assembly which will incur wires of different thickness, soldered connections and connectors, meaning that the IR readings can and will vary. It is important to always test fully charged packs. Cells should be close in value; bad or damaged cells will be immediately visible as the difference will be large.

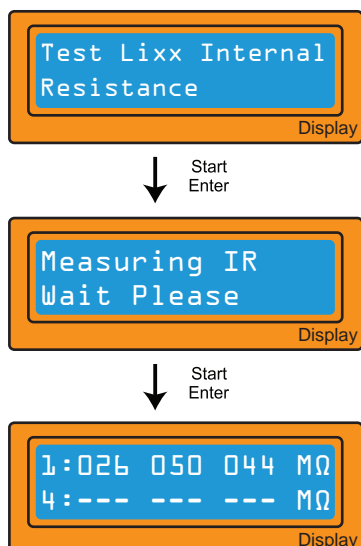

Select the interface for Internal Resistance Testing. Press **Start/Enter** to enter into it.

Press **INC** to check the total IR data of the battery pack. Press **INC** again to view the data of individual cells. This screen shows an example of what a reading of a faulty cell may look like.

10. Save Data program

The VSRmini has a data storage program that allows the user to store up to 5 battery data settings, that can then be easily loaded up and reused, saving the user from having to input all of the correct settings again.

To set up the parameter values that you wish to save, press **Start/Enter** to make the value blink then use **INC** or **DEC** to find the value you want and then **Start/Enter** again to select.



Program Select

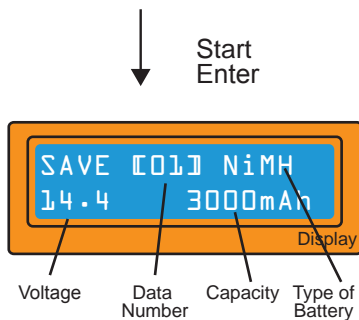

This screen shows the specifications of the battery you wish to charge. This example shows a 3000mAh 12S NiMH battery pack.

<Batt type stop >
Start > 3 seconds
Enter

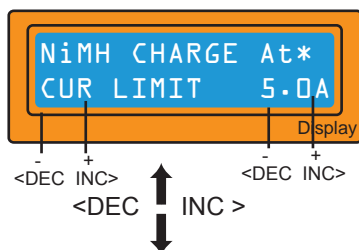

Here you can set up the charge current for the manual charge mode, or the current limit for the automatic charge mode. Each mode can be switched by pressing **INC** and **DEC** at the same time when the current field is blinking.

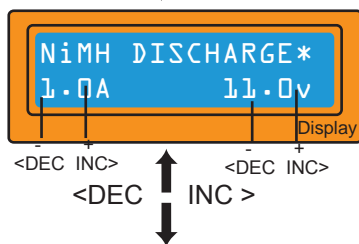

On this screen the user can set the desired discharge current and final voltage.

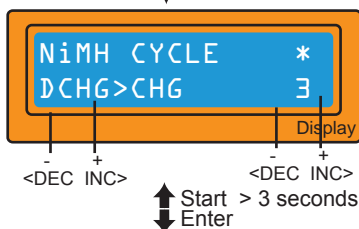

Then you can chose whether you want to cycle your NiMH pack. Select the sequence and the number of cycles you wish to carry out.

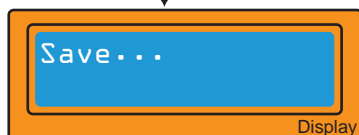

Press **Start/Enter** to save all of the parameters.

11. Load Data program

This program calls back the data that was stored at 'Save Data' program. To load the data, press **Start/Enter** once to make the number field and blink, and then select the number using **INC** or **DEC** key then hold **Start /Enter** for 3 seconds.



Program Select

↓
Start
Enter



Select the number of the data that you wish to load. The data saved under that number will then be displayed.

↓
Start
Enter > 3 Seconds



Loading the data

12. Program information

You can find a variety of information about the running program during the charging or discharging process. If you press **DEC** during the process the charger will display all of the user settings. If you press **INC** while the individual connection cable is linked to the Lithium battery being processed, you can monitor the voltage of the individual cells.

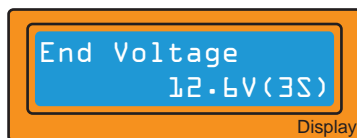

The voltage cut-off point.

< DEC ↓



The charge/discharge capacity cut-off point.

< DEC ↓



The charge and discharge time cut-off.

< DEC ↓

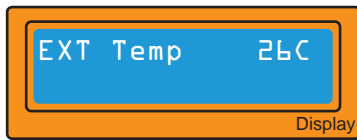

The external temperature of the battery pack (will only be displayed when using a temperature probe not included with the charger - sold separately).



To utilise this feature, the battery pack must have a balance lead that's linked to each of the cells. If the battery is correctly connected to the charger you can check the voltage of each individual cell in the battery pack. When you have connected the cable to the port on the right side of the charger, this program shows the voltage of each cell (6 cells maximum) in sequence.

13. Warning and error messages

The RC6-VSR is fitted with a variety of protective features in order to maximise safety. If a problem occurs, a noise will sound and an error message describing the issue will appear on the screen.



The output is connected to a battery with incorrect polarity.



The battery is not connected to the charger correctly, or has been disconnected mid-charge.



The charger has short-circuited. Please check the charging leads.



The input power voltage has dropped below the minimum limit.



The voltage of the battery pack was selected incorrectly. Verify the voltage of battery pack carefully.



The charger has malfunctioned.

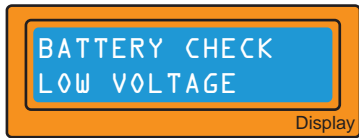

The processor detects the voltage is lower than what has been set. Please check the cell count of the battery pack.

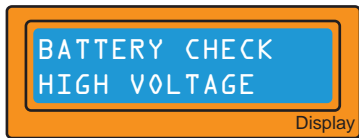

The processor detects the voltage is higher than what has been set. Please check the cell count of the battery pack.

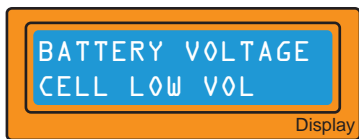

The voltage of one of the cells in the Lithium battery pack is too low. Please check the voltage of the cells one by one.



The voltage of one of the cells in the Lithium battery pack is too high. Please check the voltage of the cells one by one.



The individual connector is not connected correctly. Please check the connector and cables carefully.



The internal temperature of the unit is too high. Please wait for the unit to cool down.



The processor cannot continue to control the feeding current. The unit needs to be repaired.



The battery balance port or the power line to the connector is not set up properly. Please check connections and cables.

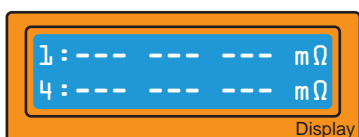



This product must not be disposed of with other waste. Instead, it is the user's responsibility to dispose of their waste equipment by handing it over to a designated collections point for the recycling of waste electrical and electronic equipment. (WEEE) The separate collection and recycling of your waste equipment at the time of disposal will help to conserve natural resources and ensure that is recycled in a manner that protects human health and the environment

The Waste Electrical and Electronic Equipment (WEEE) Directive is now UK law. The legislation aims to make producers pay for the collection, treatment and recovery of waste electrical equipment. The regulations also mean that suppliers of equipment like high street shops and internet retailers must allow consumers to return their waste equipment free of charge.

The amount of WEEE we throw away is increasing by around 5% each year, making it the fastest growing waste stream in the UK.

- Much of the UK's WEEE ends up in landfill, where the lead and other toxins it contains can cause soil and water contamination. This can have a harmful effect on natural habitat, wildlife and also human health.
- Many electrical items that we throw away can be repaired or recycled. Recycling items helps to save our natural finite resources and also reduces the environmental and health risks associated with sending electrical goods to landfill.

Distributors of new Electric and Electronic Equipment (EEE) have a part to play in reducing the amount of WEEE going into landfill sites.

Overlander Batteries is obliged under these regulations to offer our customers free take-back of their WEEE on a like-for-like basis when they buy a new Electrical or Electronic product from us.

Goods are marked with this symbol to show that they were produced after 13th August 2005, and should be disposed of separately from normal household waste so that they can be recycled.

If you have any more questions regarding battery recycling please feel free to contact us.

Under the Waste Battery regulations, Overlander Batteries are also now offering a take back scheme for all portable waste batteries. You can return your waste batteries to our business premises in person (please do not post). Alternatively, you can find your local recycling facility at www.batteryback.org

CE RoHS