

13 爆炸圖 EXPLOSION

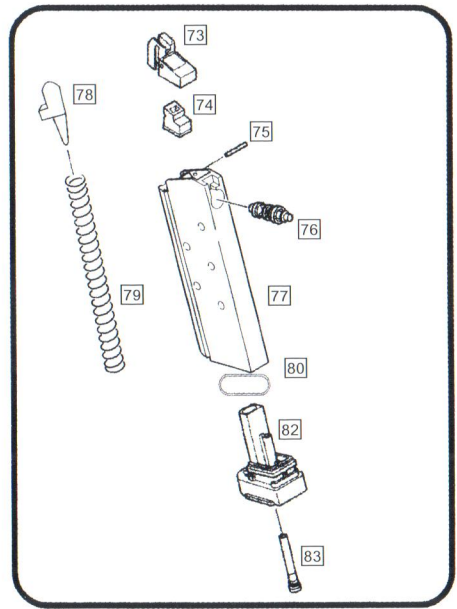
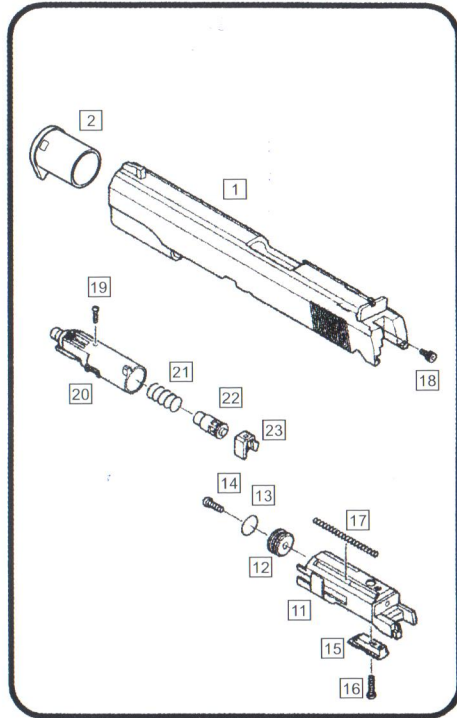
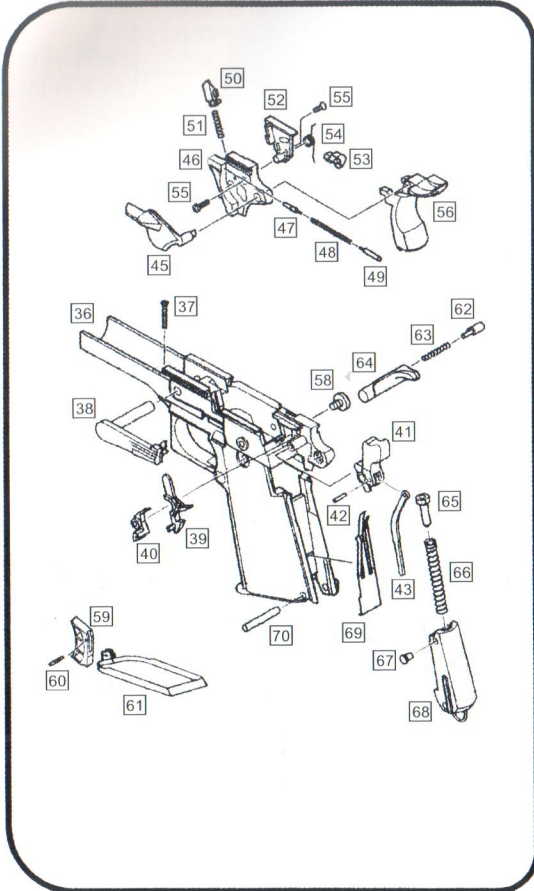
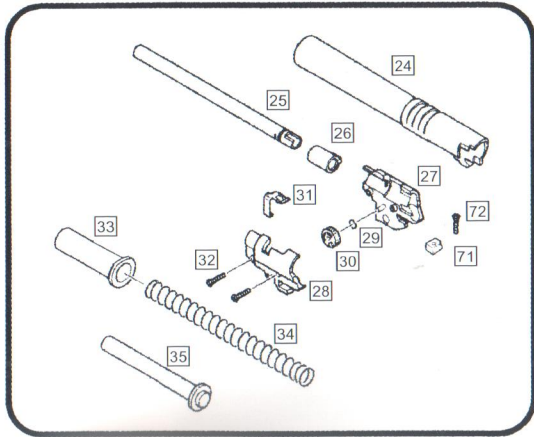

警告 ★ 正確使用空氣軟槍，可享受愉快的射擊，但是錯誤的使用方法非常危險，務必遵守下列注意事項

Caution!

PRECAUTION

NE PAS UTILISER D'AUTRES

PROJECTILEE QUE CEUX FOURNIS.

VORSICHT

Ausschliesslich für diese Pistole bestimmte

Munition verwenden.(5.5mm Kunststoffkugeln)

Fare attenzione



★ 射擊時最好戴護目鏡



☐ Be sure to wear shooting glasses or Goggle when shooting.

▲ Toujours porter des lunettes de tir ou de protection quand vous tirez.

△ Zum Schiessen stets eine Schutzbrille tragen.

■ Asegurese de llevar puestas las gafas de proteccion cuando dispare.

○ Assicurarsi di indossare lenti di Protezione quando si spara

★ 不用時要把槍置於高處 (小孩拿不到的高處)



☐ Put the gun beyond the reach of kids.

▲ Tenir hors de portee des enfants.

△ Pistole immer kindersicher aufbewahren.

■ Ponga la pistola fuera del alcance de los ninos.

○ Tenere fuori Dalla portata dei bambini.

★ 不可用眼睛探視槍



☐ Don't peep at the muzzle.

▲ Ne jamais regarder dans le canon.

△ Nie in den lauf schauen.

■ Jamas mire por el canon

○ Non guardare mai dentro la canna.

★ 不可朝人射擊



☐ Don't aim at people even if it is unloaded.

▲ Ne jamais viser quelqu'un meme si votre pistolet est vide.

△ Auch bei spiel-und Sportwaffen besteht Verletzungsgefahr. Auch ungeladen nie auf einen Menschen oder ein Tier richten!

■ No apunte a personas, incluso descargado.

○ Non puntare mai verso le persone anche se la pistola scarica.

★ 射擊的瞬間，才可以把手指接近扳機擊打



☐ Don't touch the trigger until the moment of shooting.

▲ Ne jamais appuyer sur la gachette le rearmement.

△ Abzug erst dann berühren,wenn Sie zum Schiessen bereit sind.

■ No toque el gatillo hasta el momento del disparo.

○ Non toccare il grilletto fino al momento di sparare.

★ 確定射擊的方向均安全後才可以射擊



☐ After making sure that there is nobody nearby.

▲ Toujours etre sur qu'il n y a personne dans la trajectoire de votre tir.

△ Vergewissern Sie sich vor dem Schiessen stets, dass niemand getroffen werden kann.

■ Antes de apuntar aseguese que no hay nadie cerca.

○ Assicurarsi sempre che non ci sia nessuno sulla traiettoria di tiro.

★ 避免粗魯的動作，發生危險



☐ Avoid a rough operation.

▲ Ne jamais jeter le pistolet quand il est arme.

△ Geladene Waffe stets mit Respekt

Behandln. Nicht werfen oder unsantf Jandhaben.

■ No tire ni lance la pistola, se puede disparar.

○ Evitare azioni brusche.

★ 不使用時，應將彈匣取出，並取下子彈

☐ When the gun is not in use, remove the magazine and unload BB pellets.

▲ Quand vous ne l'utilisez plus,bien Faire attention de retirer le chargeur et de le desarmer.

△ Zum Aufbewahren Magazin entfernen und Kugeln herausnehmen.

■ Cuando no se este utilizando la pistola, saque todas las bolas.

○ Quando l'arma non e in uso, estrarre il caricatore e scaricare i pallini.

