

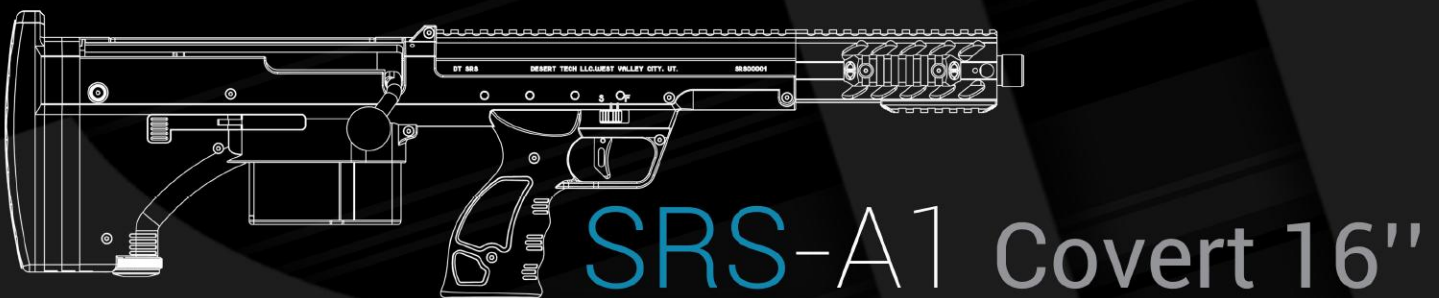

**SILVERBACK
AIRSOFT**

SRS-A1

user manual



DESERTTECH
TOMORROWS WEAPONS

SRS-A7



YouTube

<https://www.youtube.com/channel/UCDj3a3fBr4rRY025VX8D5Q>



<https://www.facebook.com/silverbackairsoft>



<http://www.silverback-airsoft.com>

TABLE OF CONTENT

SAFETY.....	3
DT & SRS PRESENTATION.....	4
BOX CONTENT.....	5
GUN DESCRIPTION.....	5
ASSEMBLY.....	6
HOPUP.....	6
BARREL.....	6
BOLT.....	7
BUTTPLATE.....	7
RAILS.....	7
SETTINGS.....	8
HOPUP.....	8
TRIGGER BOX.....	9
CHEEKPAD.....	9
BUTPLATE.....	9
UTILISATION.....	10
SAFETY.....	10
MAGAZINE.....	10
SHOOTING.....	11
MONOPOD.....	12
MAINTENANCE.....	12
OPTION SPARE PARTS.....	13
EXPLODED VIEWS.....	14
PARTS LIST.....	14
CHASSIS.....	15
STOCK.....	15
BOLT.....	16
BARRELS.....	16
MONOPOD.....	17
MAGAZINE.....	17
REGISTRATION.....	18
SERIALS NUMBERS.....	18
MATERIALS.....	18
SIZE/WEIGHT.....	18

SAFETY

READ THIS MANUAL CAREFULLY BEFORE USE, users should obey to laws regarding usage and ownership of airsoft guns in their country. Misuse or careless use may cause serious injury. Always treat airsoft gun as if it is loaded and with the same respect as you would treat a firearms. Don't look into the airsoft gun muzzle. Never point the airsoft gun at something you don't intend to shoot. Users should always wear safety glasses. Always carry this airsoft gun in a bag or a case and never display it in public places. Always keep the airsoft gun safety on "safe" position until ready to shoot in a safe direction. Always check that the airsoft gun safety is on "safe" position and unloaded when getting it from another person or from storage. Don't put this airsoft gun away or in storage while loaded. Don't shoot at hard surfaces or at a water surface as bbs could bounce or ricochet and hit someone or something you were not intending to hit. Always use high quality 6mm plastic bbs and never use already shot bbs, it might damage your airsoft gun. Always store this airsoft gun in a secure position, out of reach of children. Don't modify or alter your airsoft gun, attempt to modify the airsoft gun may make you airsoft gun unsafe to use and/or cause serious injury and/or void the warranty. **WE'RE NOT RESPONSIBLE FOR ANY MALFUNCTION, ACCIDENTS, INJURIES OR REPAIR COST RESULTING FROM MISUSE, DISASSEMBLY AND/OR MODIFICATION OF THIS AIRSOFT GUN.**



DESERTTECH®

TOMORROWS WEAPONS

Desert Tech, formerly Desert Tactical Arms, has been building a better rifle since 2007 when we realized the demands of future battlefields exceeded the capabilities of current platforms. We decided then to build our rifles more accurate, more compact, more convertible for an increasingly complex world.

Our R&D department is tasked daily to fuse ground-breaking engineering with American ingenuity so that skilled machinists on state-of-the-art mills and lathes can shape battle-tested materials into Tomorrow's Weapons. Each Desert Tech rifle that enters our network of nationwide dealers and international distributors is both ergonomically and ballistically superior to any other production rifle on the planet.

Desert Tech also offers select, premium, match-grade munitions as well as world-class precision instruction across the 25,000 acres of natural terrain and sophisticated training bays at our private facility. These features compliment a complete package of detail-driven customer service for the modern-day warrior, hunter or competition shooter who demands peak performance with each and every trigger press of a Desert Tech SRS, Covert, HTI or MDR.

From concept to recoil, we are creating uncommon and uncompromising firearms with the sole intent of arming serious shooters to the very edge of their abilities and beyond. At Desert Tech, we're building Tomorrow's Weapons and it begins with a better rifle today.

The Stealth Recon Scout A1 (SRS-A1) is the most versatile Sniper Rifle system in the world. It is nearly a foot shorter than conventional sniper rifles, maintains 1/2 MOA or better accuracy with DTM Ammunition, and can be easily adapted to individual mission requirements by changing the weapon's caliber and length. Whether a police sniper is shooting 50 yards or a military sniper is shooting a mile the SRS offers unrivaled flexibility in a package shorter than the M16 battle rifle.

Accuracy

The SRS achieves superb accuracy in all calibers because it's built around core accuracy components:

1. Match grade (free-floated) barrels, chambers, and crowns
2. High quality match trigger
3. Solid, repeating return-to-zero barrel mounting system (the receiver securely clamps around the first six inches of barrel)

Quick Caliber Conversion

The SRS is quickly convertible between the following calibers: .308 Winchester (22" and 26" barrels), .260 Remington, 6.5x47 Lapua, 7mm Winchester Short Mag, .300 Winchester Magnum, .338 Norma Magnum, and .338 Lapua Magnum. The caliber conversion and return to zero is simple and takes less than 60 seconds.

Benefits:

1. Operators can change rifle length, penetration, and distance capabilities.
2. Snipers can shoot various ammo calibers and types depending on METT-T.
3. Snipers can progressively train on more powerful ammo.
4. Reduced training costs (train and practice with .308 WIN)
5. Reduced system down-times (the operator can change his own barrels).

Compact

The SRS is the shortest purpose-built sniper rifle in the world. The telescoping bolt and bullpup configuration make it almost a foot shorter than conventional Mauser-style turnbolt sniper rifles. The compact design shifts weight and center-of-gravity rearward, creating a perfectly balanced and relatively short sniper rifle.

Rugged

The SRS was designed to operate under the harshest conditions and abuse. It is built of high-impact polymers; aircraft grade aluminum (ANSI 7075-T6); ultra high-strength steels; and some of the most durable coatings known to man. The monolithic receiver serves as a full length mounting chassis, eliminating the need for any sort of receiver-to-stock bedding interface. Ergonomic stock panels attach directly to the receiver.

The SRS maintains its accuracy and reliability in virtually any environment, including subzero arctic temperatures, extreme desert heat and dust, and wet jungle environments.



Nicholas E Young



BOX CONTENT

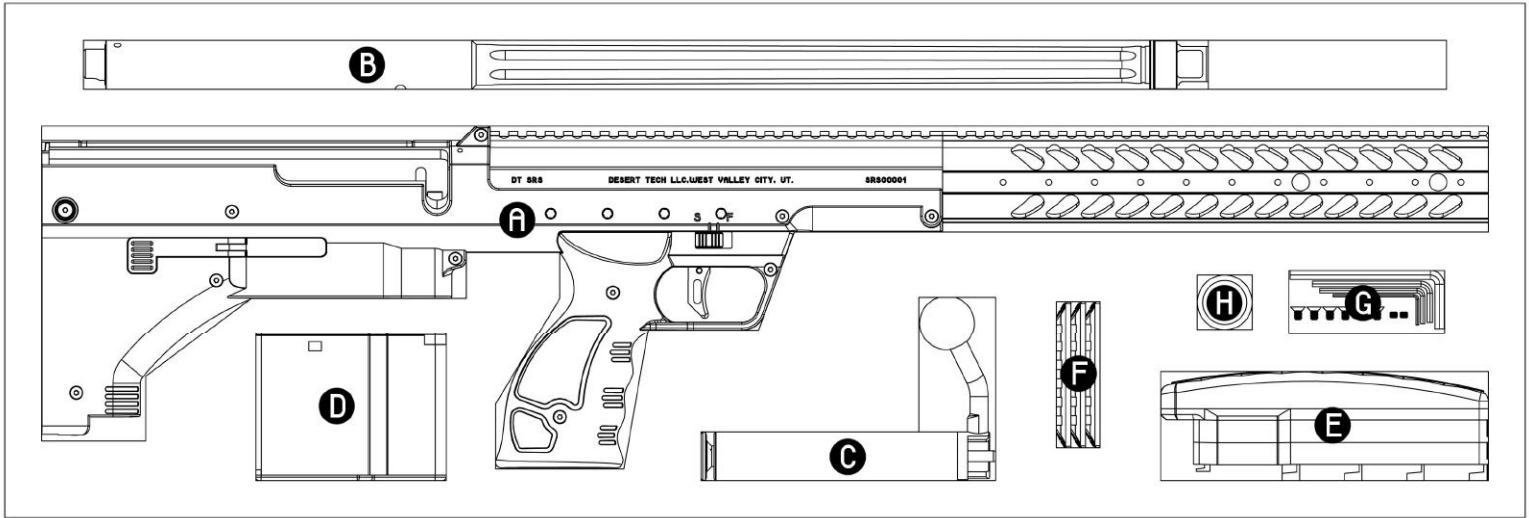

A gun body, **B** barrel, **C** bolt, **D** magazine, **E** buttplate, **F** rails, **G** tools set & screws set, **H** grease

GUN DESCRIPTION

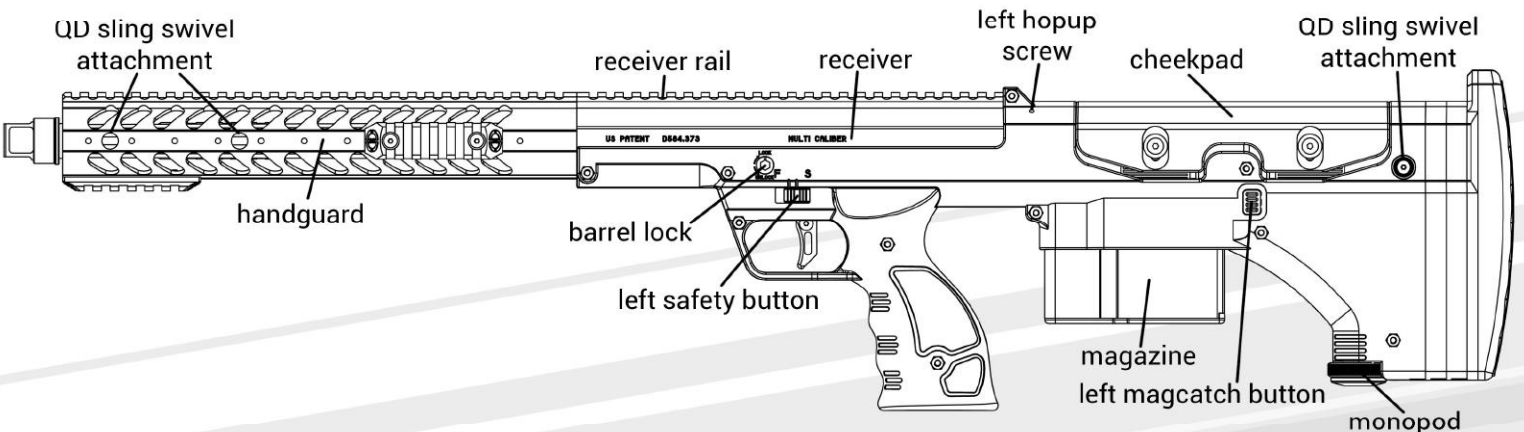
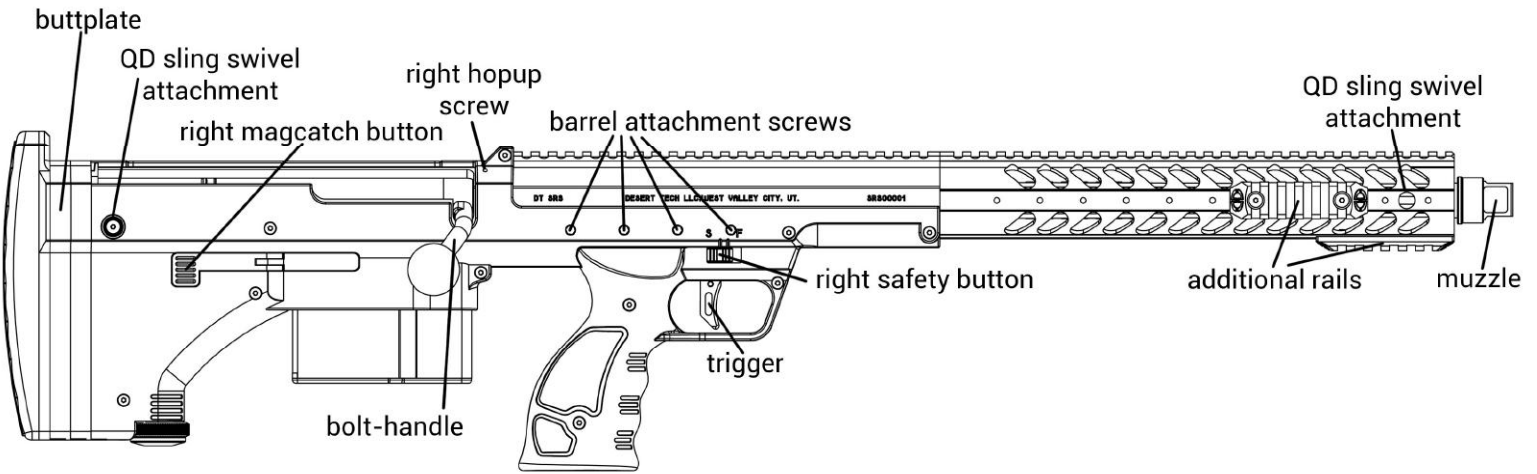

ASSEMBLY

HOPUP

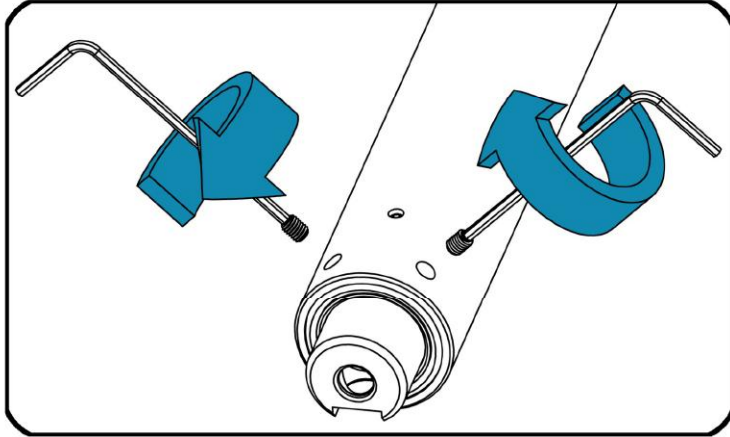

- 1 Install the two hopup screws (M3x4) from the screw set bag.

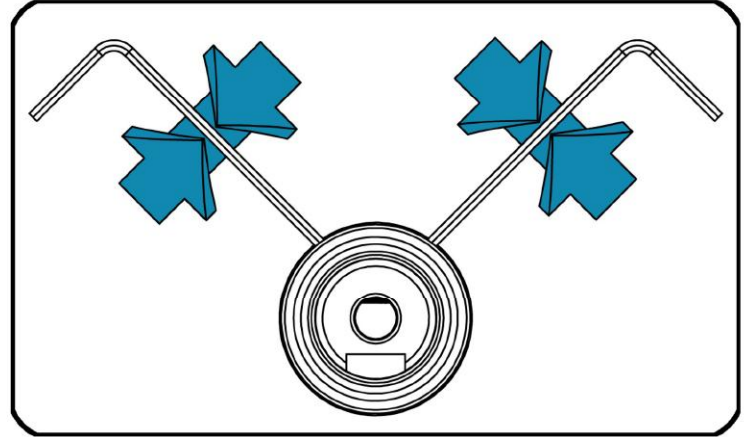

- 2 Finely tune the hop up setting (flat hop up rubber as shown here).

⚠ If hopup action is too weak, bbs won't hold the correct position in the chamber, if hopup action is too strong, jamming could occur.

BARREL

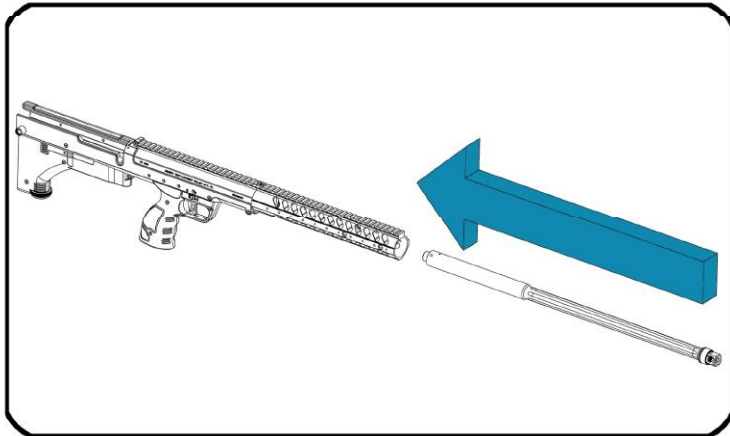

- 1 Gently insert the barrel inside the receiver.
- ⚠ Make sure that the barrel lock is on «UNLOCK» position. Make sure the bolt is remove or is not in forward position.

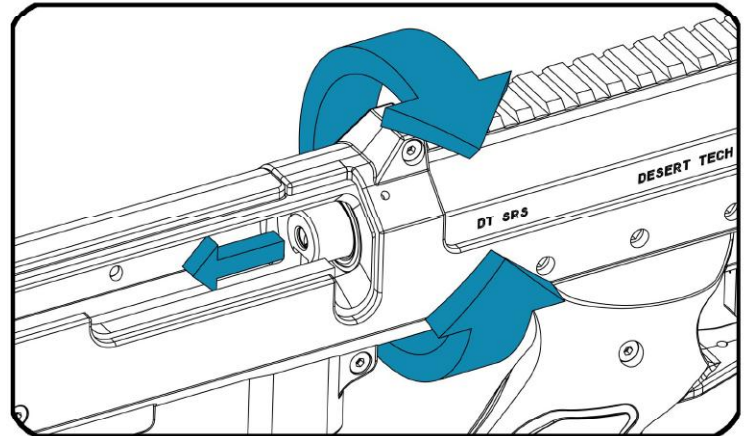

- 2 Rotate and slide the barrel until the hopup fits onto the BB-tube.

⚠ DO NOT APPLY EXCESSIVE FORCES ONTO THE BB-TUBE

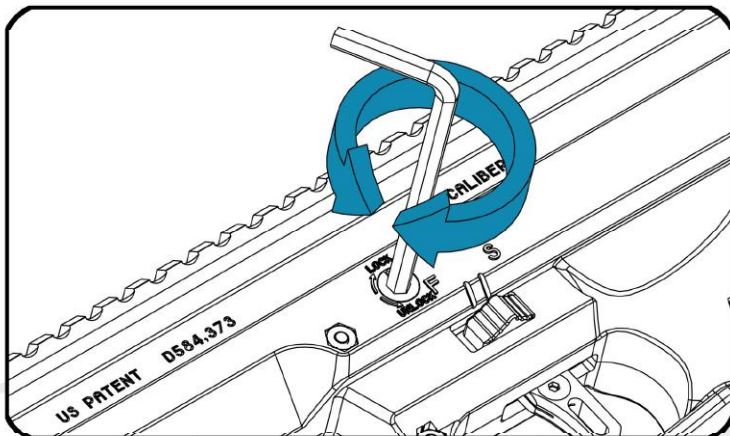

- 3 Set the barrel lock to «LOCK» position.

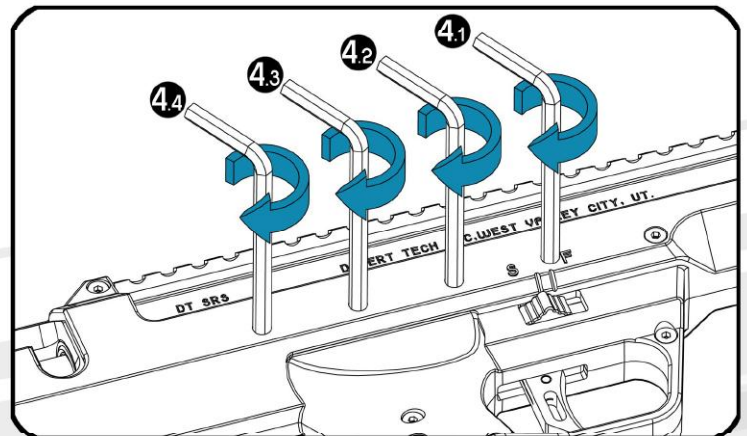

- 4 Secure the barrel by tightening the 4 barrel screws, from muzzle to bolt side (and reverse order for removal).

BOLT

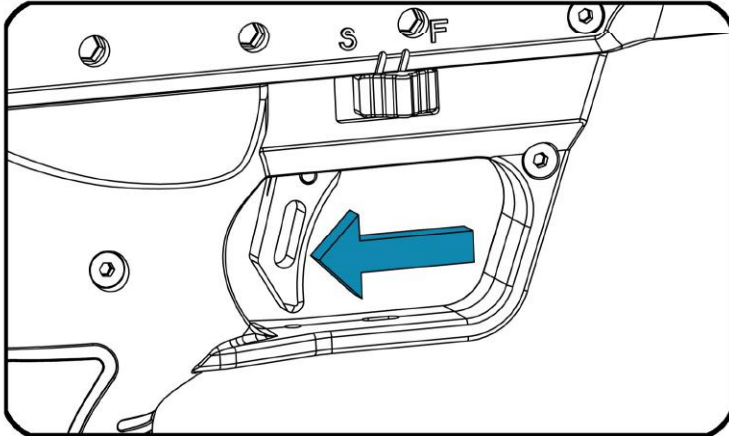

- 1 Pull the trigger.
- ⚠ Make sure that safety is off before pulling the trigger.

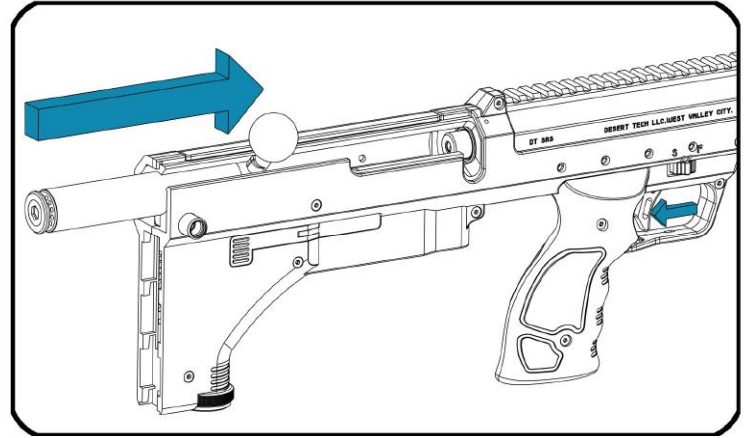

- 2 While pulling the trigger, fully engage the bolt inside the receiver.

BUTTPLATE

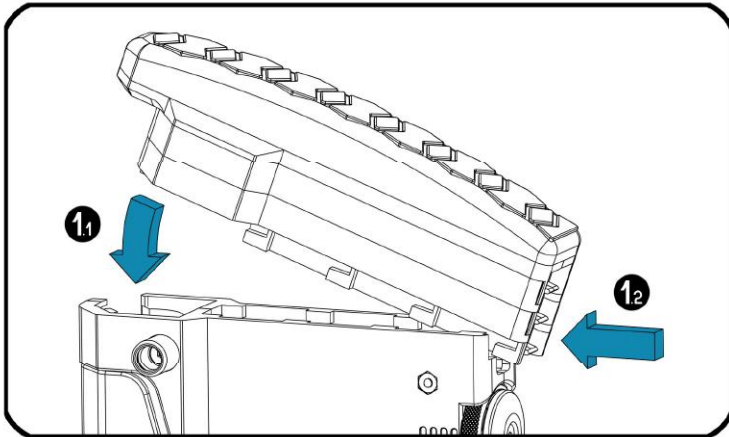

- 1 Engage the buttplate by the bottom side, then slide it up.

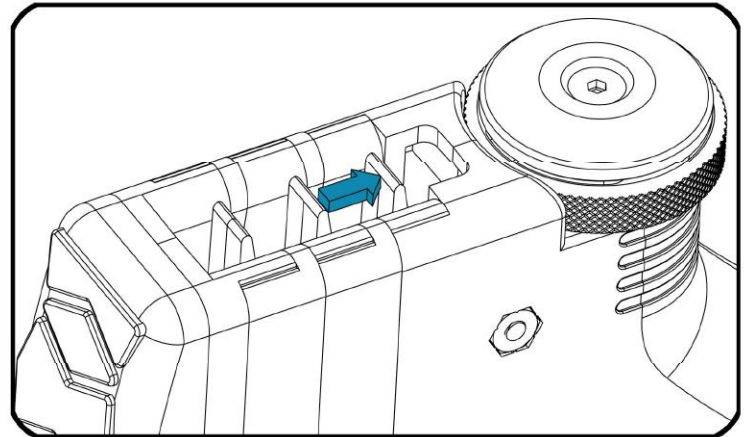

- 2 Make sure that the tap is in lock position.

RAILS

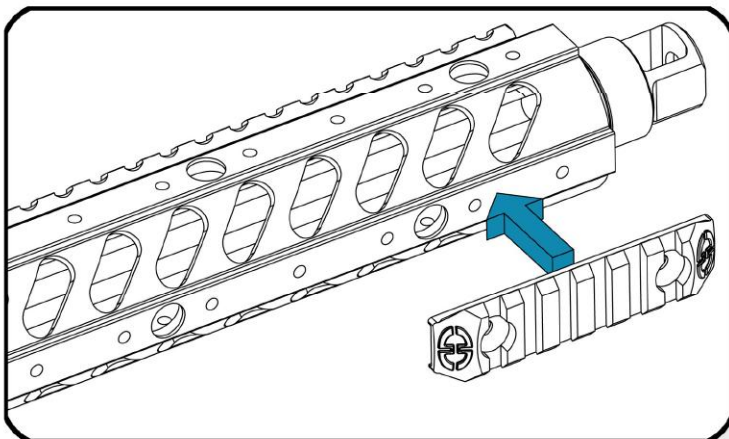

- 1 Install the rail on the handguard in the desired position

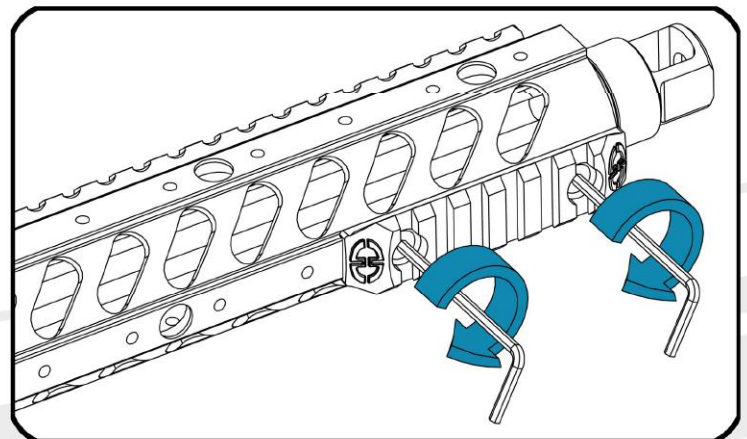

- 2 Secure the rail using two M4x7 screws from the screw set bag.

SETTINGS

HOPUP

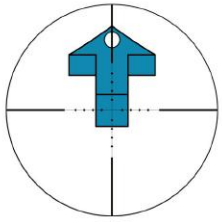

Case #1: too much hopup effect without side spin:
untight both hopup screws.



Case #2: too much hopup effect with right side-spin:
untight right hopup screw.

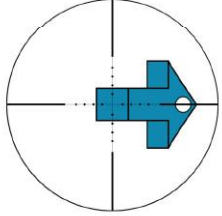

Case #3: good hopup effect with right side-spin:
untight right hopup screw, tight left hopup screw.

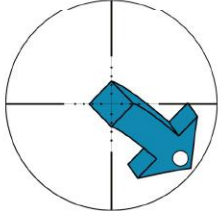

Case #4: not enough hopup effect with right side-spin:
tight left hopup screw.

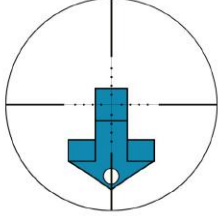

Case #5: not enough hopup effect without side-spin:
tight both hopup screws.



Case #6: not enough hopup effect with left side-spin:
tight right hopup screw.

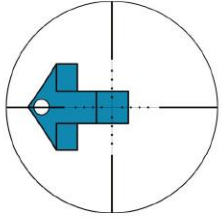

Case #7: good hopup effect with left side-spin:
tight right hopup screw, untight left hopup screw.

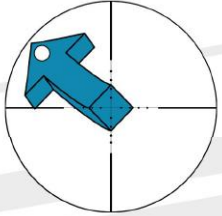

Case #8: too much hopup effect with left side-spin:
untight left hopup screw.

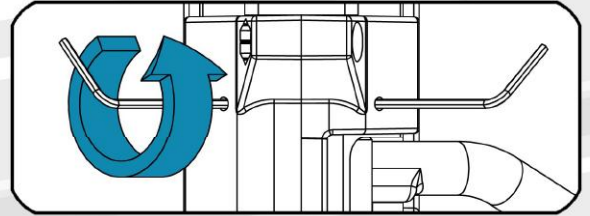
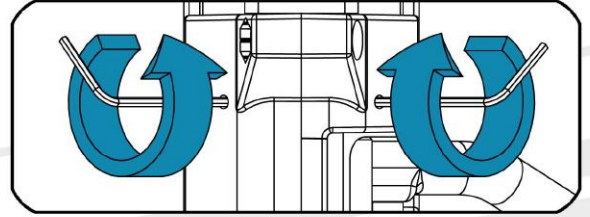
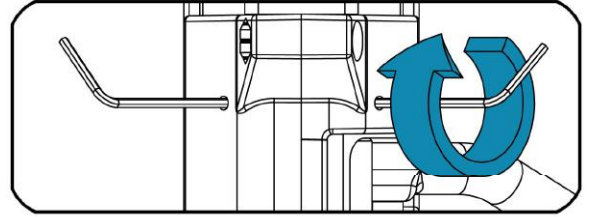
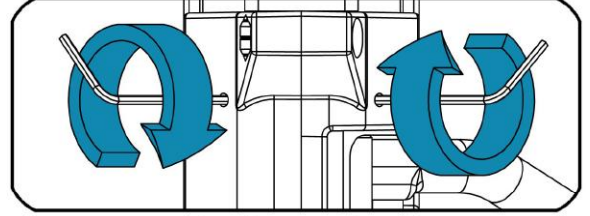
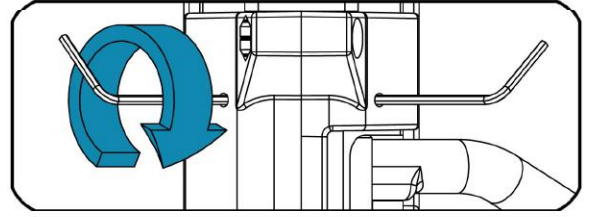
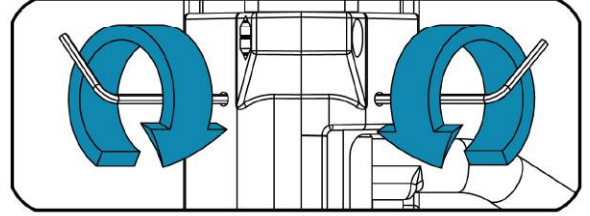
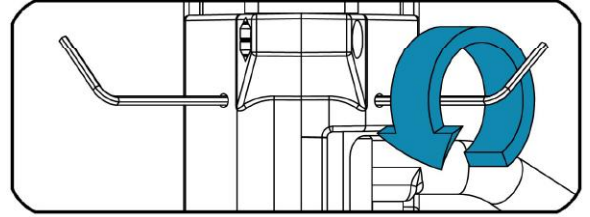
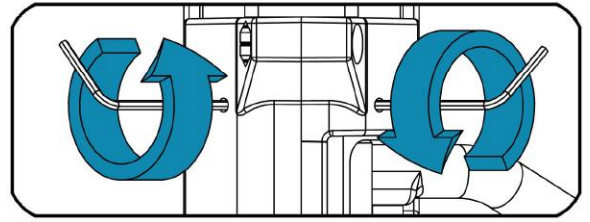

TRIGGER BOX

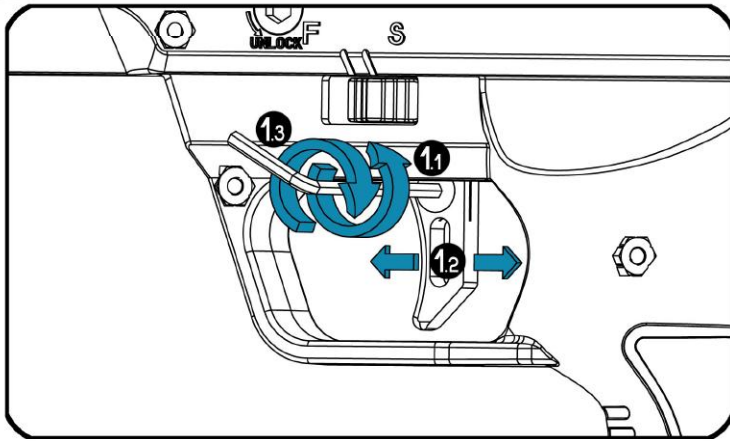

- 11 Untight the M3x6 screw to loose the trigger.
- 12 Adjust the trigger position.
- 13 Tight the M3x6 screw to lock the trigger.

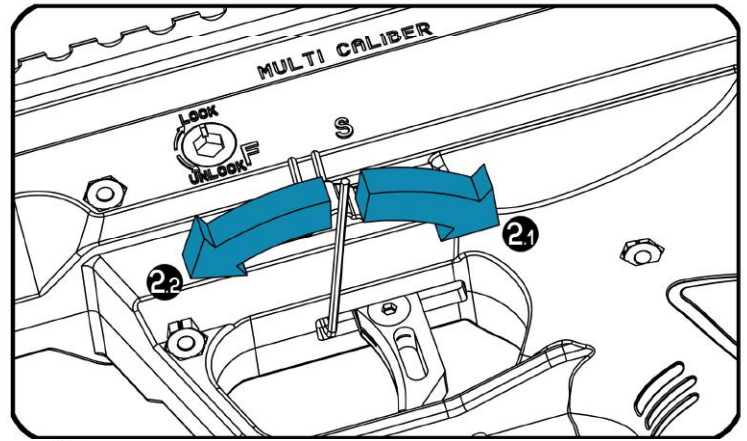

- 21 Tight the M3x12 screw to increase trigger preload (reducing trigger pull weight).
- 22 Untight the M3x12 screw to decrease trigger preload.
- ⚠ Excessive preload will disable safety use, further excessive preload will disable safe piston sear action.

CHEEKPAD

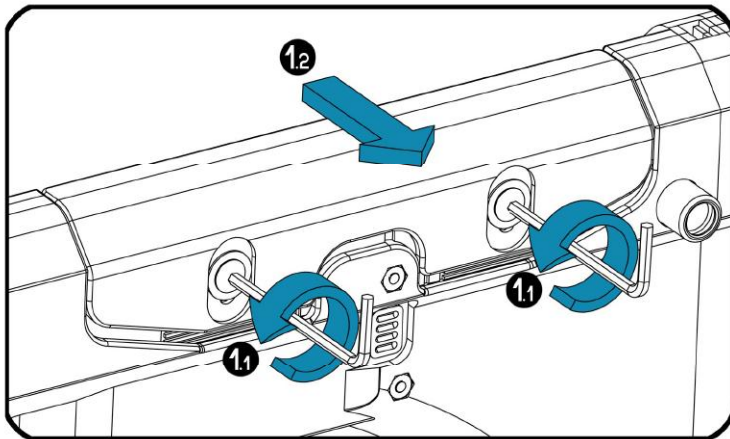

- 11 Untight the two M5x6 screws.
- 12 Slide the cheekpad in the proper direction.

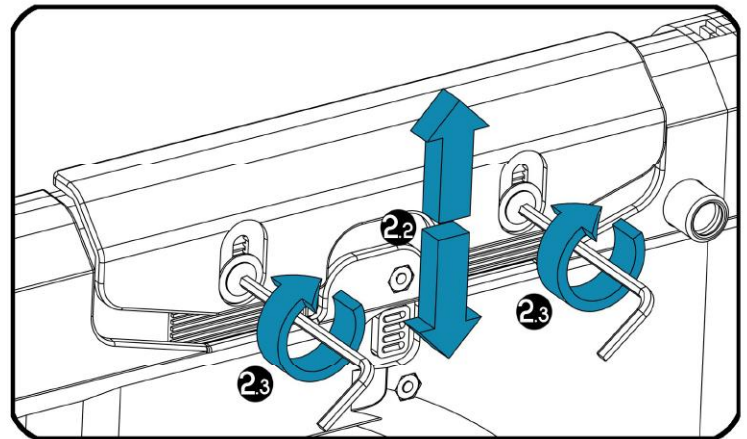

- 22 Adjust the cheekpad position (six positions allowed).
- 23 Tight the two M5x6 screws to lock cheekpad.

BUTTPLATE

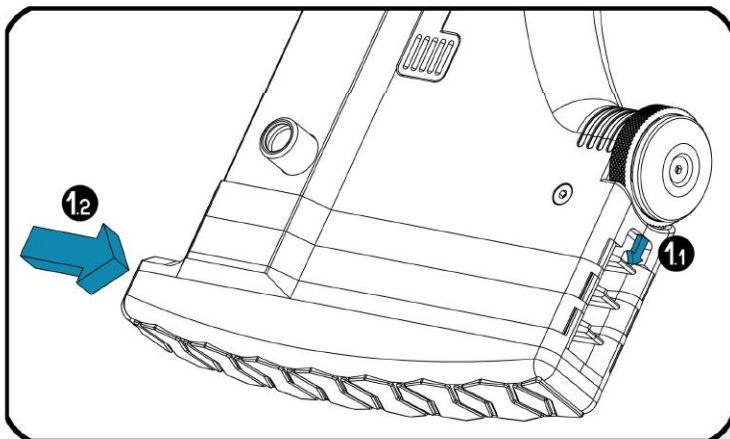

- 11 While pushing the tap backwards,
- 12 push the buttplate down to remove it.
- ⚠ Make sure that the bolt is in forward position before pushing the buttplate.

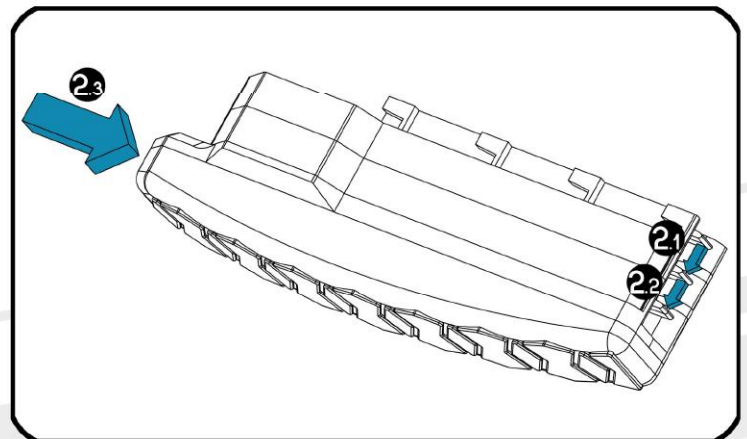

- To remove one layer of spacer, push the tap 21 while pushing the buttplate down 23.
- Do same with the second tap 22 to remove two layers.

OPERATION

SAFETY

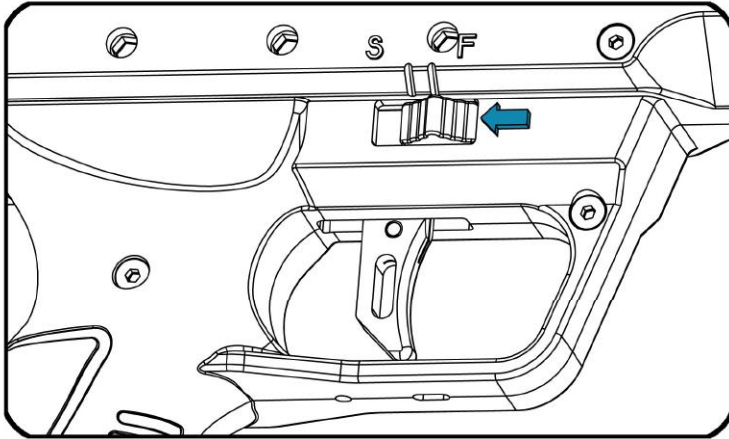

- 1 Slide the safety button (right or left) to «S» position to engage the safety.

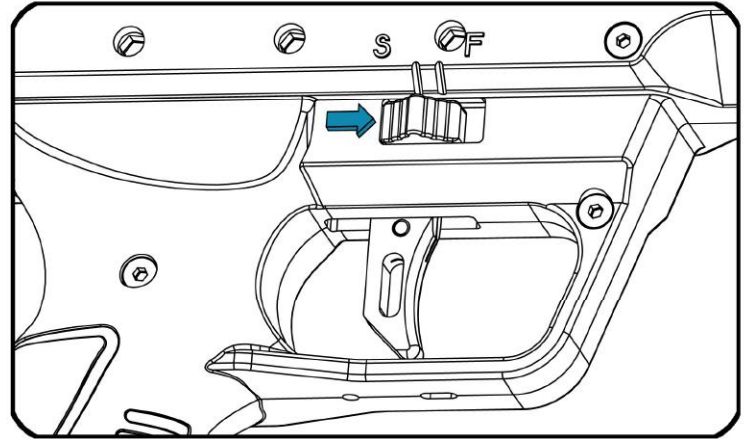

- 2 Slide the safety button (right or left) to «F» position to disengage the safety.

MAGAZINE

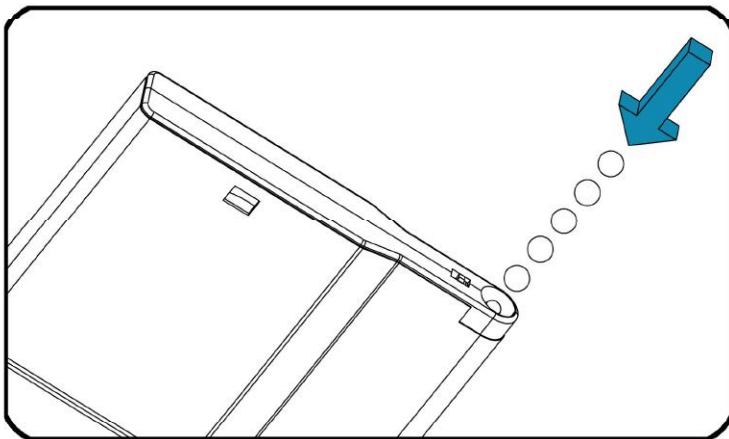

- 1 Insert 6 mm plastic bbs inside the magazine (by hands or using a bb-loader).
Magazine capacity : 30 bbs.

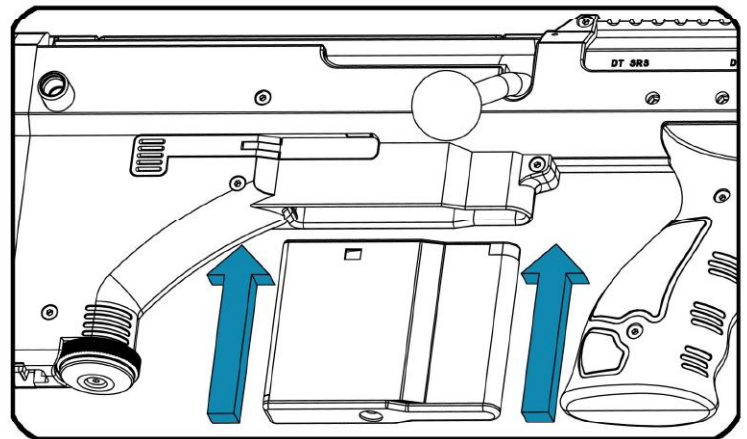

- 2 Engage the magazine firmly to ensure correct magcatch action. An oring is inserted in the bb-tube, avoiding bbs to fall while removing the magazine. This oring may cause a few bbs to remain in the magazine.

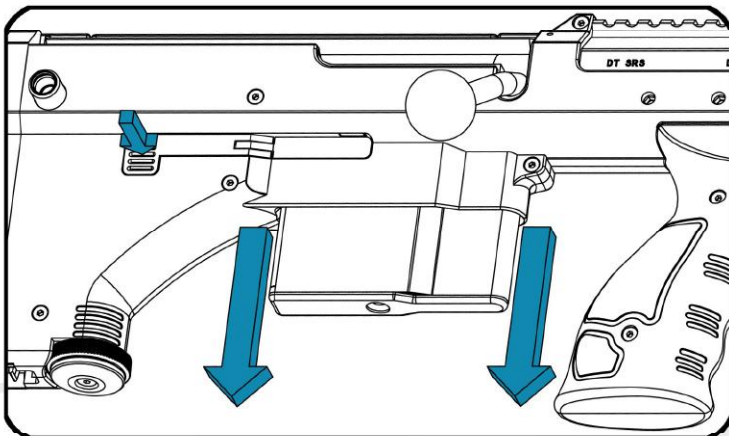

- 3 To remove the magazine, pull down the magazine while pushing the right magcatch button

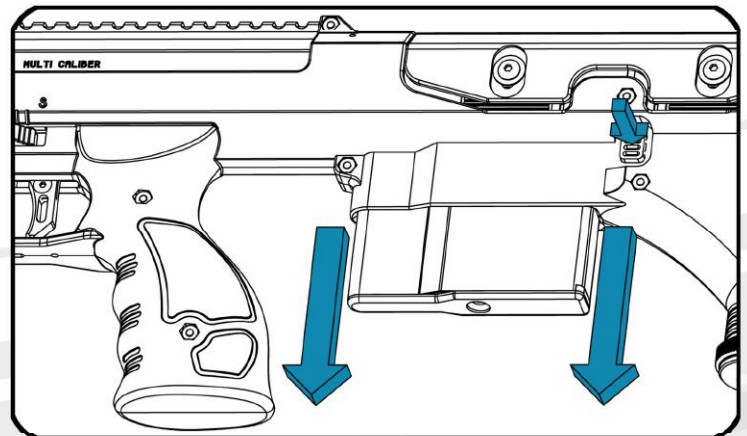

- 4 You can also remove the magazine using the left magcatch button.

SHOOTING

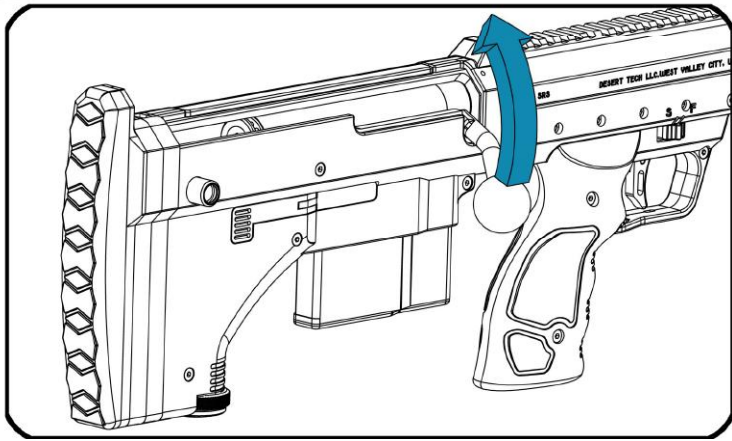

1 Pull up the bolt handle.

⚠ Make sure that the bolt is not already armed to avoid sudden bolt movement.

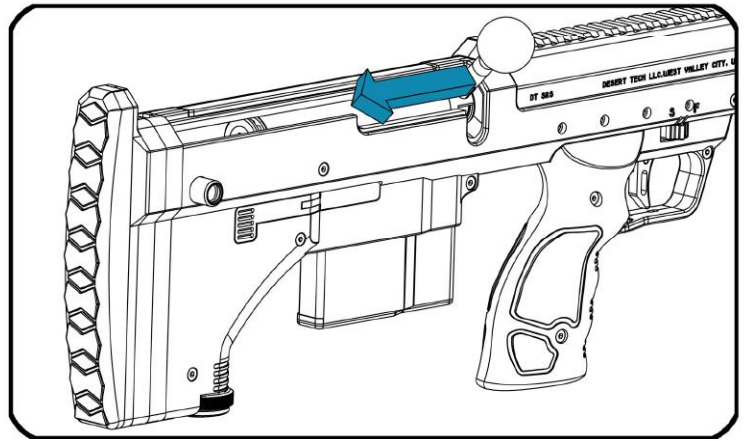

2 Move the bolt backward to lock the piston sear (until it clicks).

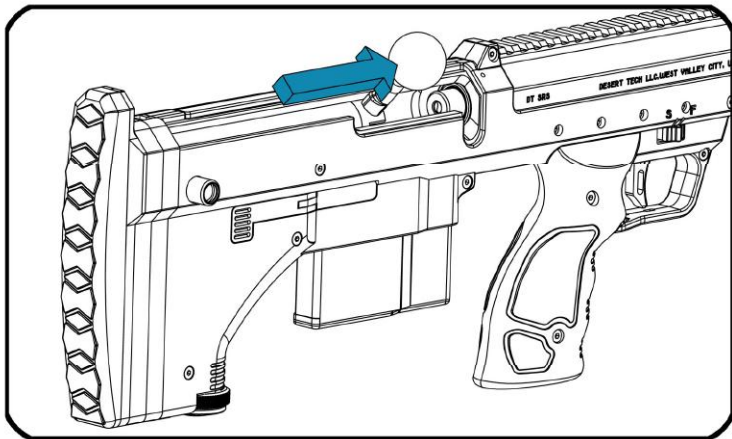

3 Push the bolt forward to compress the spring.

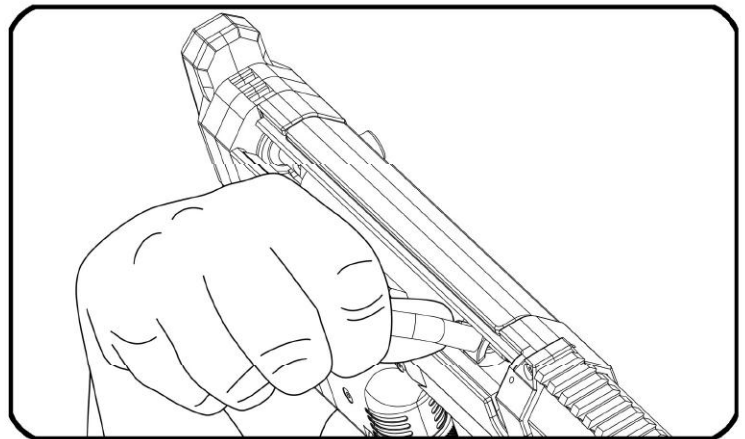

4 We advise you to push the bolt with your thumb in the indicated position in order to ease the movement.

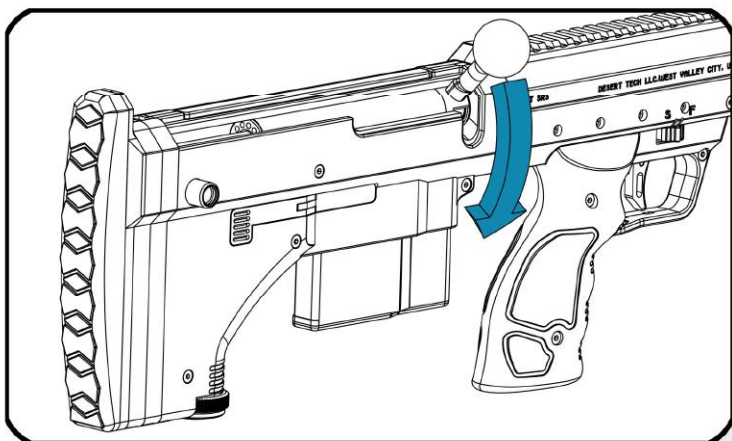

5 Lock down the bolt handle to lock the bolt.

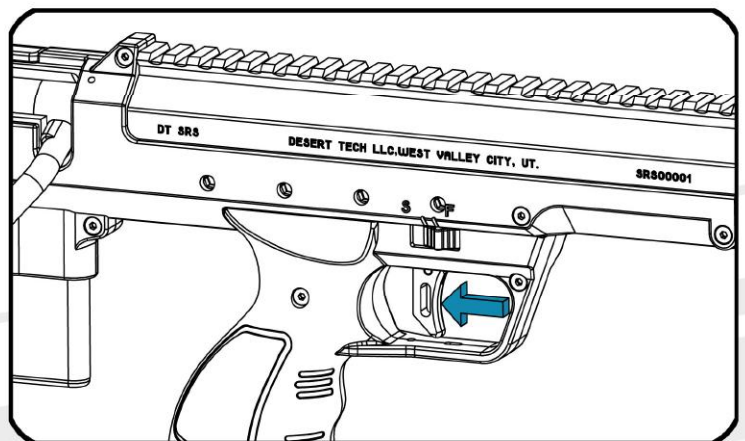

6 Pull the trigger to shot.
⚠ Be sure safety is off.

MONOPOD

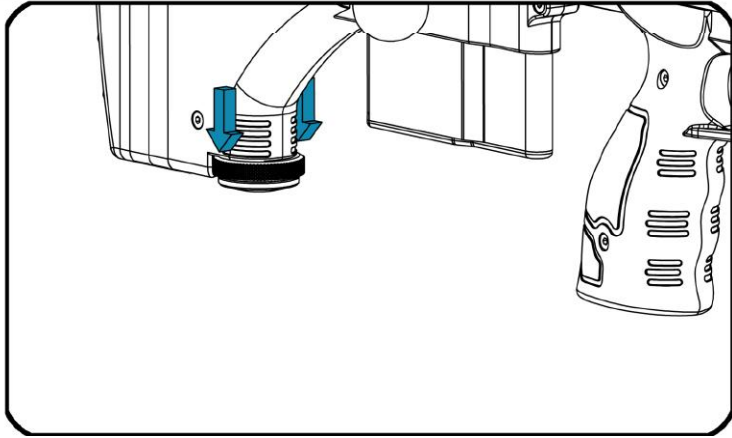

1 To release the monopod, pull down the monopod knob.

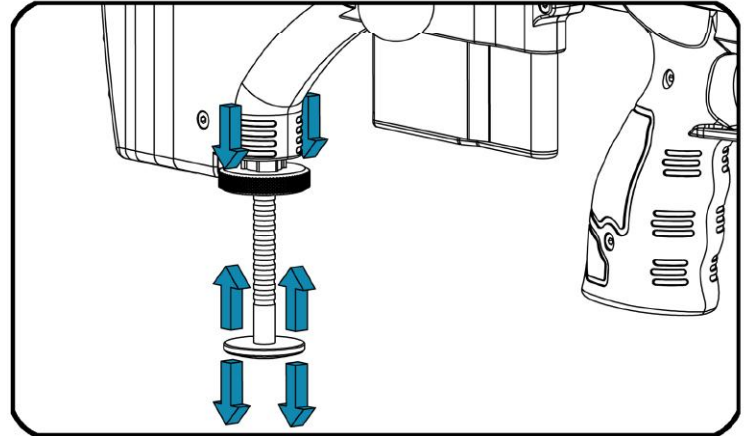

2 For fast adjustment, push up/down the monopod foot while the monopod knob is lowered.

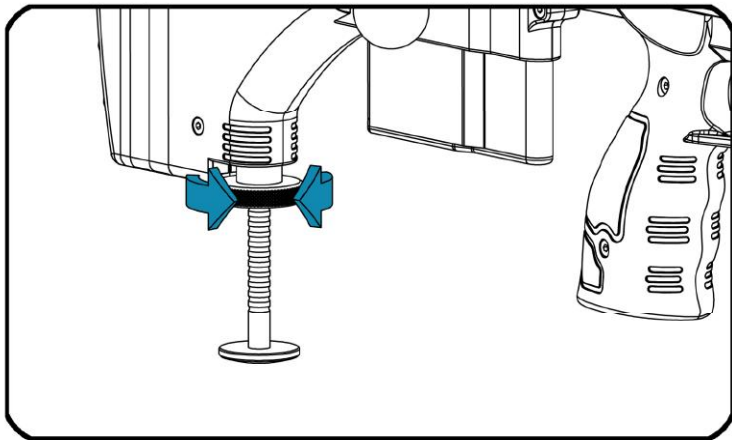

3 For fine adjustment, turn monopod knob clockwise to add elevation, turn monopod knob counter-clockwise to remove elevation.

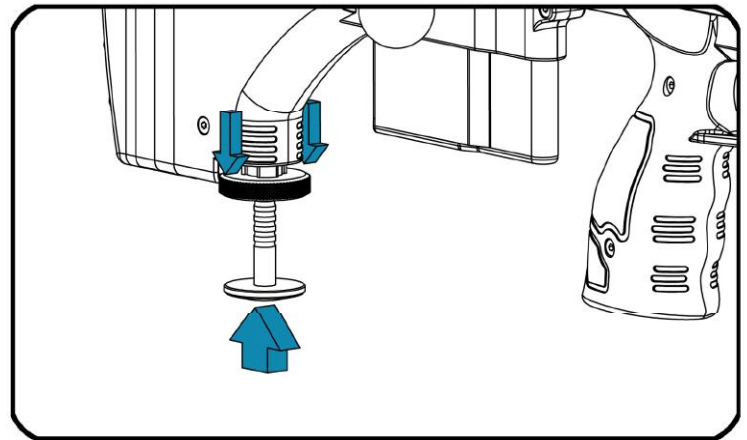

4 In order to return in original position, push up the monopod foot while the monopod knob is lowered.

MAINTENANCE

GREASING/OILING

Bolt assembly does require, at regular intervals, degreasing, cleaning and an even and moderate greasing for optimum performances. We suggest you to use a grease of the same type as the one provided with your SRS replica, silicone with PTFE. Steel parts need greasing to avoid rust: bolt assembly, QD sling attachment, mag catch, magazine steel case. Avoid oiling or greasing at all time on following parts: nozzle, hop up, inner barrel and magazine internal. Oiling or greasing of those parts will have negative effect on hop up efficiency and shooting accuracy.

CLEANING (BARREL/HOPUP)

Inner barrel and hop up unit must be perfectly clean to ensure optimum performances and accuracy, we suggest you to use a small cotton ball soaked in a non corrosive solution (alcohol or plastic/rubber friendly degreasing chemical) and push it through the inner barrel with a plastic rod from muzzle to hop up. Repeat this operation with a new soaked cotton ball until this one remains clean. We advise you to perform this operation on this airsoft gun before first use.

STORAGE

After use, remove all bbs from the magazine to relieve pressure on the magazine spring. Empty remaining BBS in the bb tube for safety reason, put the replica upside down, and load all BBS by incomplete bolt movements (no locking the piston sear). When BB-tube is empty, expel all bbs by shooting in a safe direction. We recommend you to remove the bolt assembly from your replica for storage, or at least to disengage the bolt from the "armed" position, with nozzle out of the hop up unit in order to relieve pressure on hopup internal orings, ensuring long lasting air seal.

OPTION SPARE PARTS

- A** Steel Magazine (30 rounds)
- B** Bolt (1.7 J)
Bolt (0.9 J)
- C** Handguard long
- D** Handguard covert
- E** 26" barrel with hopup unit
- F** 22" barrel with hopup unit
- G** 16" barrel with hopup unit
- H** Additional rails (3 pieces)
- I** -14 muzzle brake for QD silencer
- J** -14 muzzle brake .338
- K** -14 thread protection
- Nylon stock panels black
- Nylon stock panels FDE
- Nylon stock panels OD
- L** Buttplate spacer (1 piece)
Buttplate spacer (3 pieces)
- M** Hopup unit
- N** QD silencer for .308 muzzle brake
QD silencer + .308 muzzle brake

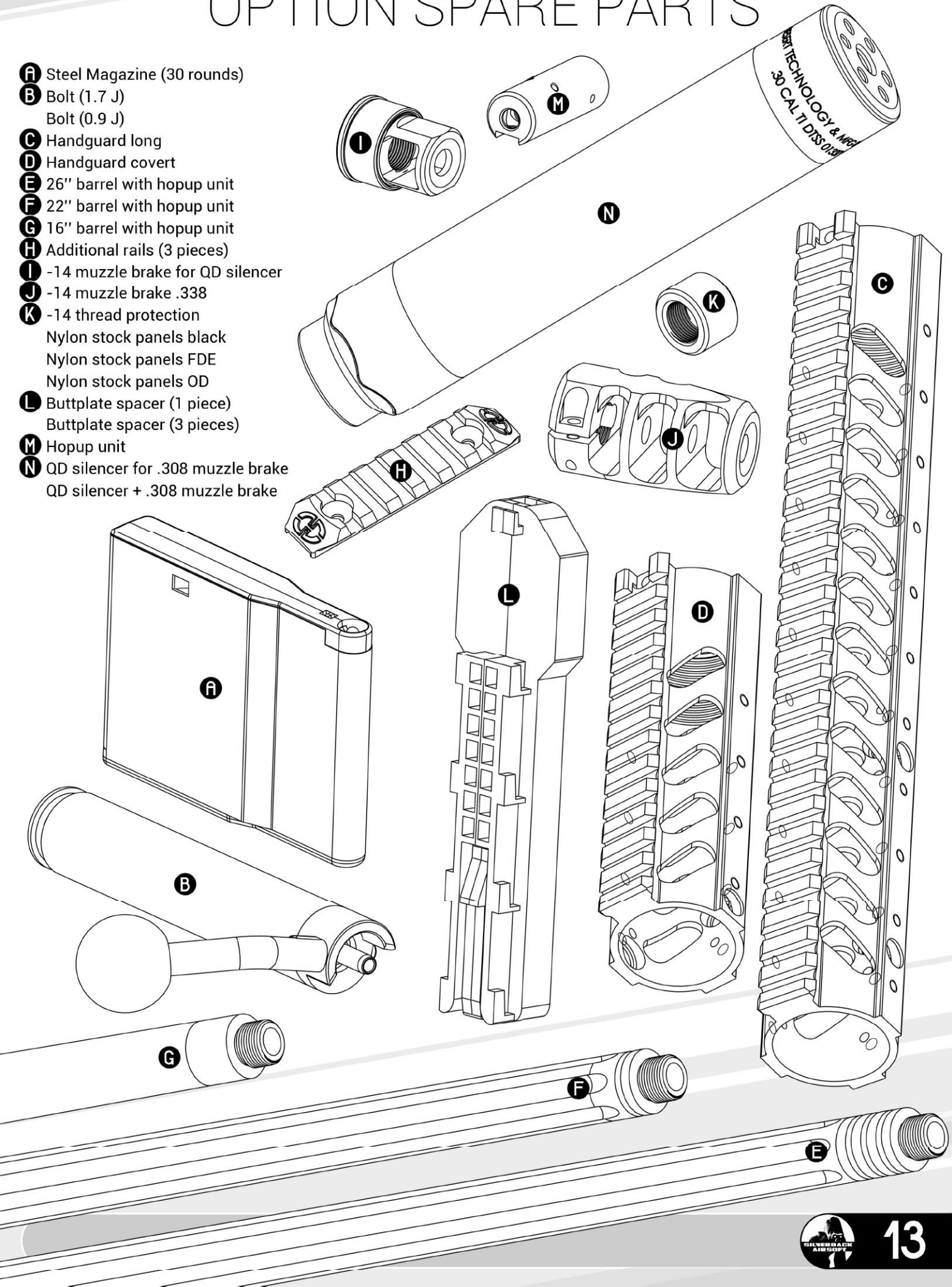

EXPLODED VIEWS

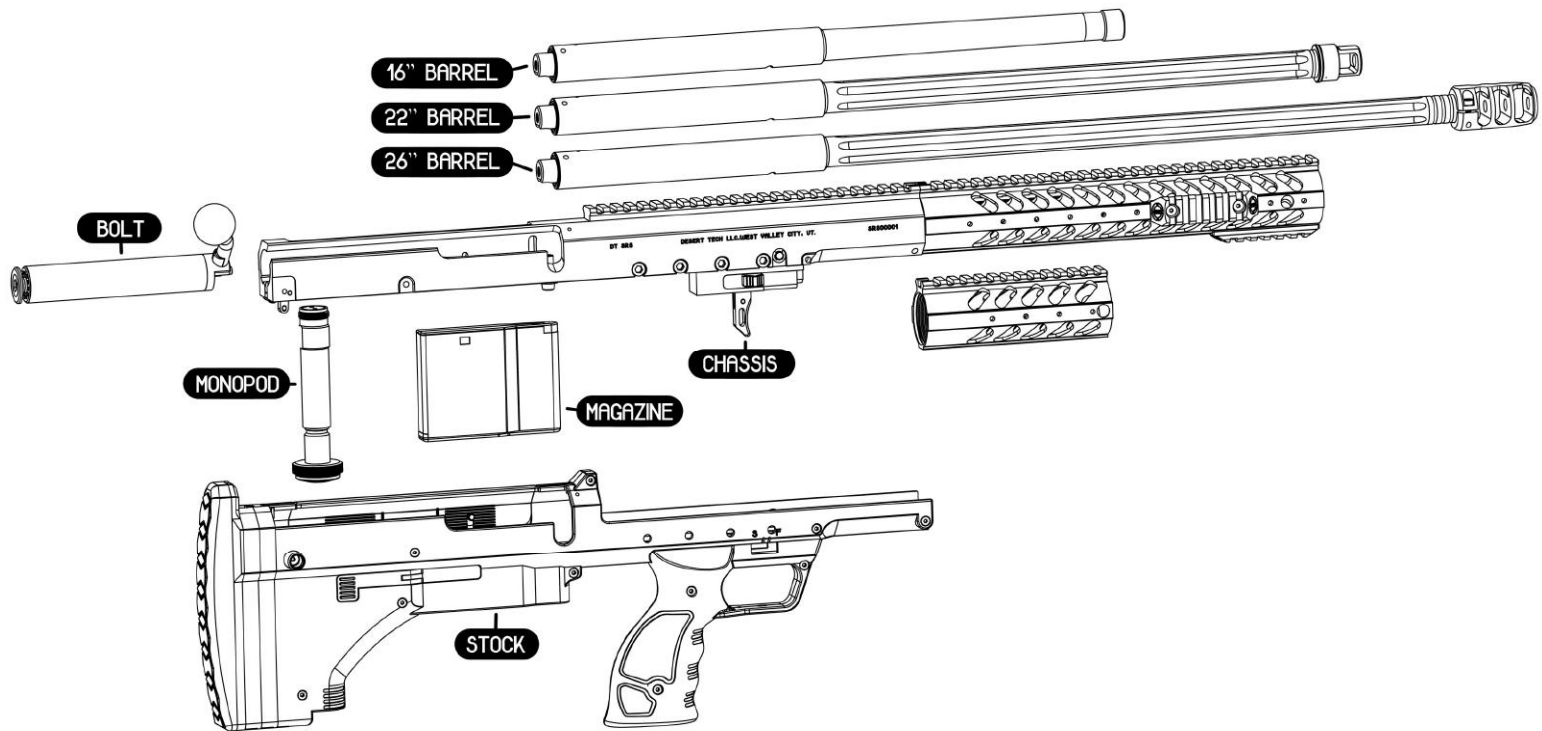

PARTS LIST

Chassis

SRS101	receiver
SRS102	handguard covert
SRS103	handguard long
SRS104	handguard lock
SRS105	rail
SRS106	barrel lock
SRS107	bbs tube
SRS108	trigger box
SRS109	trigger box axis
SRS110	trigger base
SRS111	trigger
SRS112	safety
SRS113	rod
SRS114	piston sear
SRS115	piston sear axis
SRS116	spring plate

Stock

SRS201-BK	stock panel right BK
SRS201-FDE	stock panel right FDE
SRS201-OD	stock panel right OD
SRS202-BK	stock panel left BK
SRS202-FDE	stock panel left FDE
SRS202-OD	stock panel left OD
SRS203	buttplate spacer
SRS204	buttplate back
SRS205	buttplate damper
SRS206	QD sling clip
SRS207	magcatch
SRS208	magcatch axis short
SRS209	magcatch axis long
SRS210	magcatch button right
SRS211	magcatch button left
SRS212	cheekpad

Bolt

SRS301	cylinder
SRS302	cylinder head
SRS303	cylinder end
SRS304	nozzle
SRS305	bolt handle
SRS306	bolt knob
SRS307	piston head
SRS308	trust bearing
SRS309	piston body
SRS310	piston end
SRS311	M95 spring
SRS312	M130 spring

Barrels

SRS401	outer barrel 16"
SRS402	outer barrel 22"
SRS403	outer barrel 26"
SRS404	inner barrel 420 mm
SRS405	inner barrel 578 mm
SRS406	inner barrel 680 mm
SRS407	hopup body
SRS408	hopup rubber
SRS409	-14 thread protector
SRS410	-14 .308 muzzle brake for QD silencer
SRS411	muzzle brake protector
SRS412	-14 .338 muzzle brake

Monopod

SRS501	monopod first houssing member
SRS502	monopod second houssing member
SRS503	monopod third houssing member
SRS504	monopod extension shaft
SRS505	monopod footpad
SRS506	monopod spring guide
SRS507	monopod knob
SRS508	monopod hat

Magazine

SRS601	magazine shell
SRS602	magazine internal right
SRS603	magazine internal left
SRS604	magazine plate
SRS605	magazine spring guide
SRS606	magazine follower
SRS607	magazine bbs stopper

CHASSIS

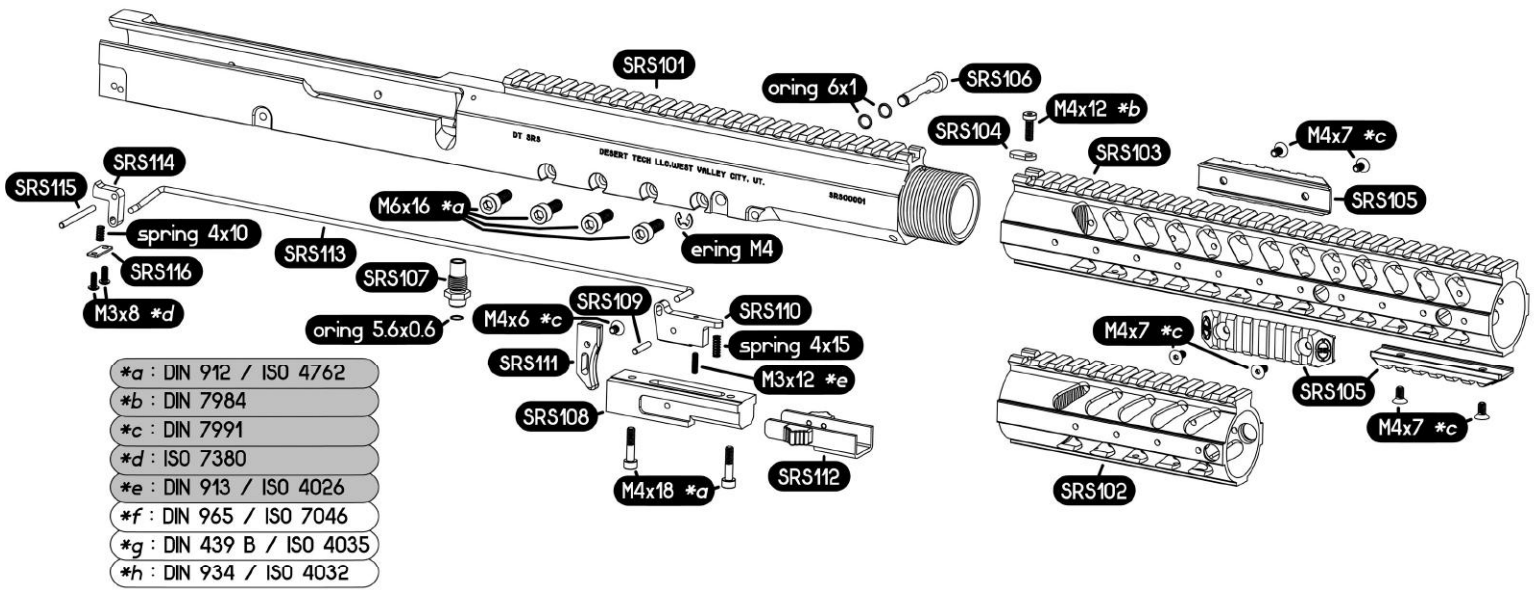

STOCK

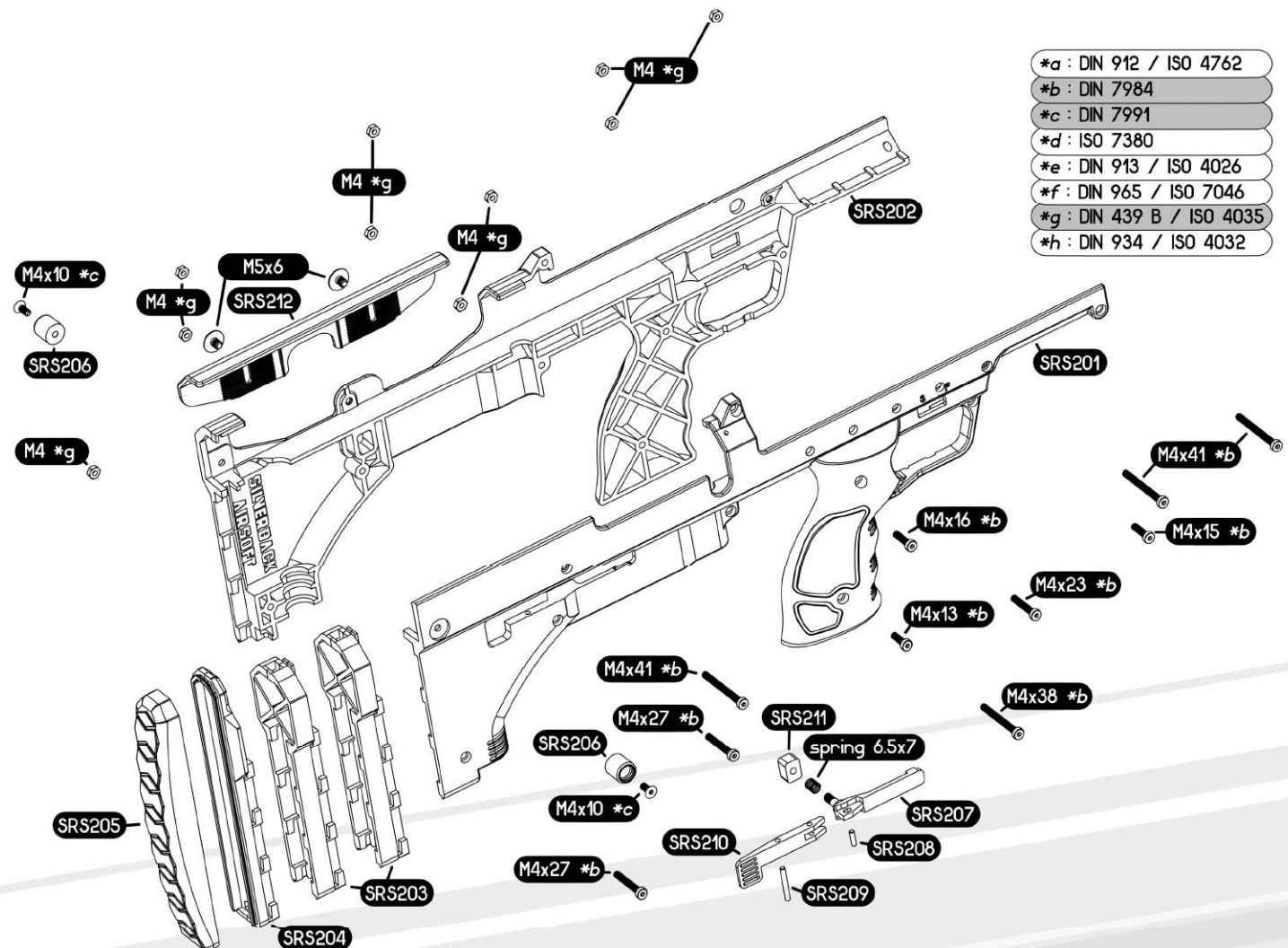

BOLT

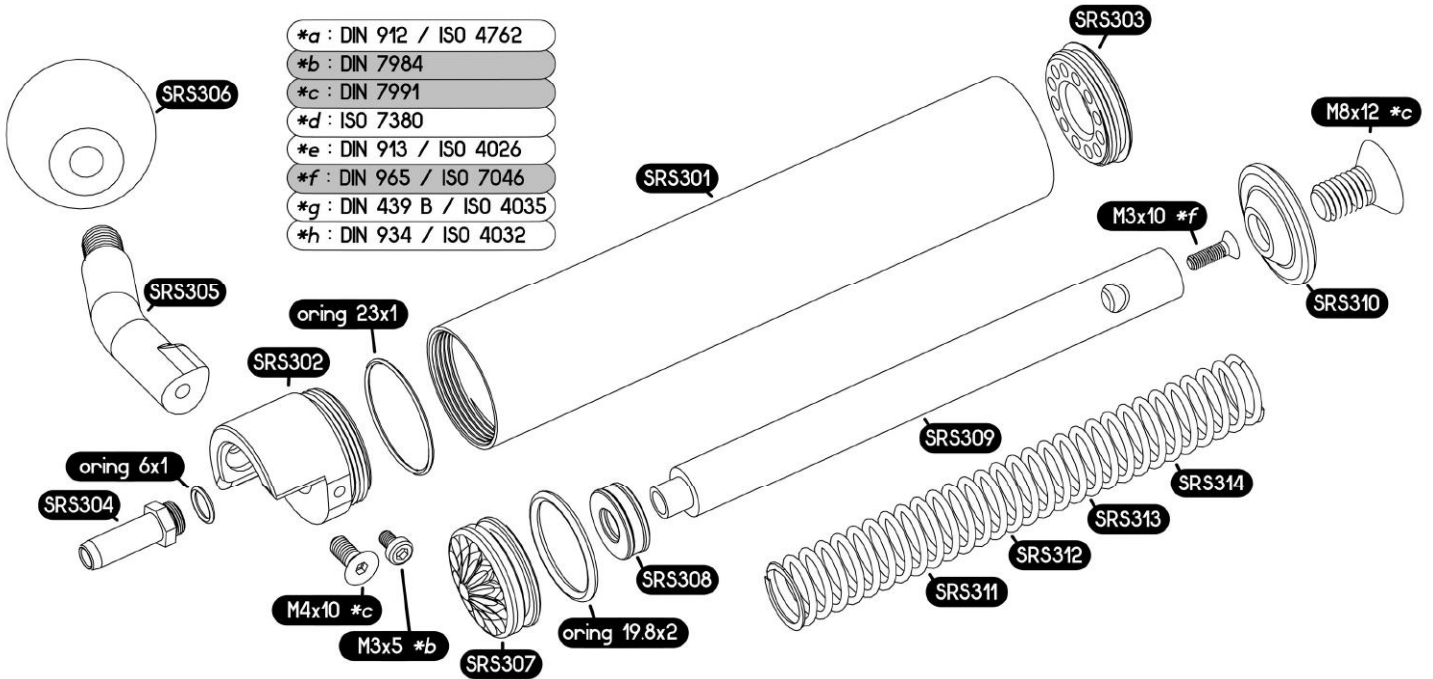

PATENT PENDING: HK1202219

BARRELS

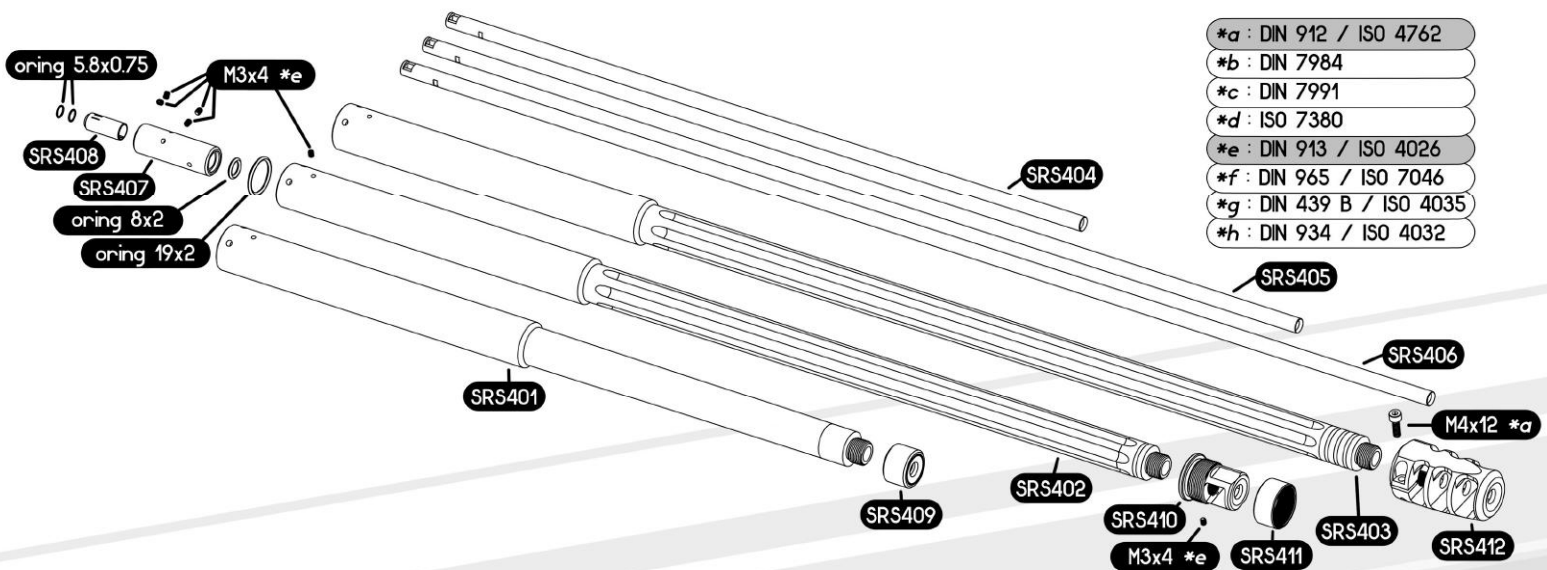

MONOPOD

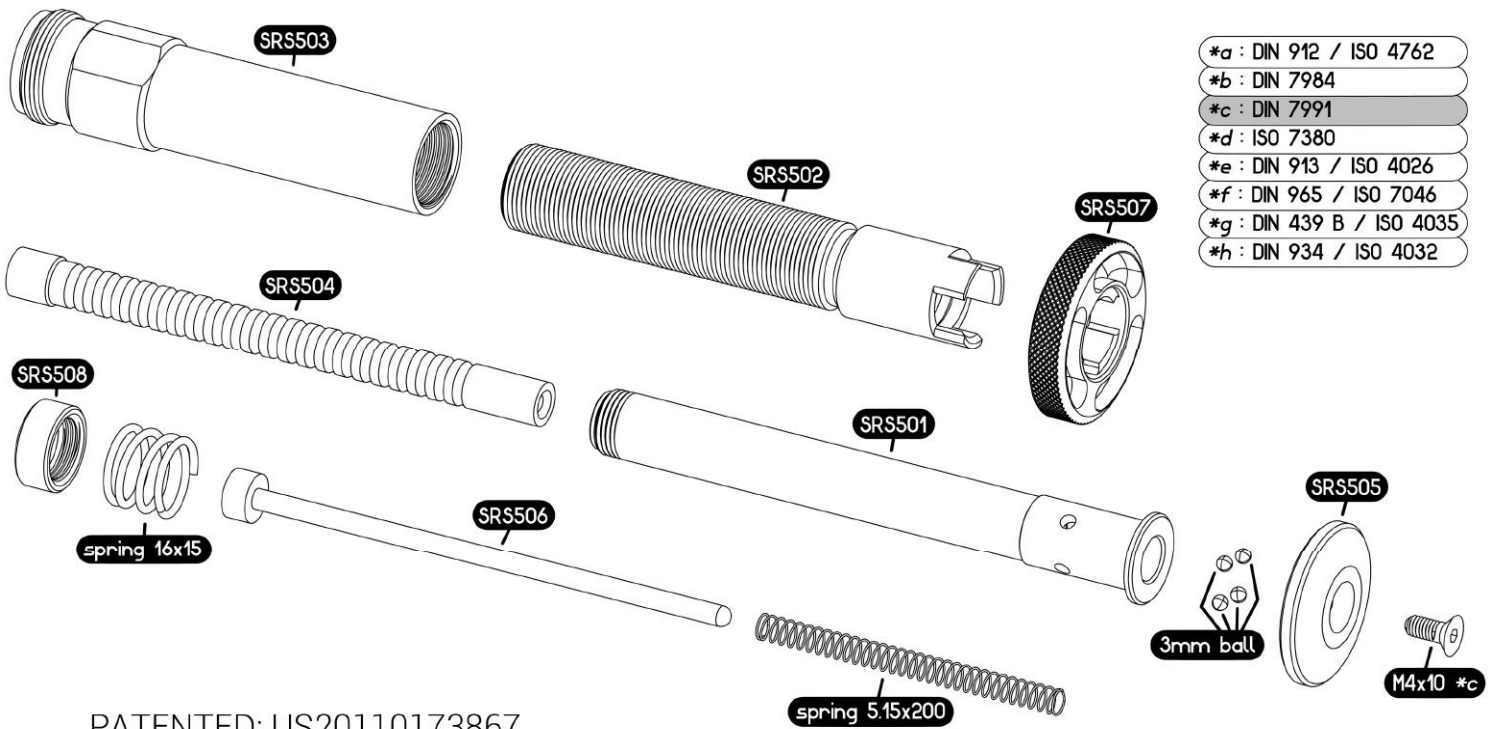

- *a : DIN 912 / ISO 4762
- *b : DIN 7984
- *c : DIN 7991
- *d : ISO 7380
- *e : DIN 913 / ISO 4026
- *f : DIN 965 / ISO 7046
- *g : DIN 439 B / ISO 4035
- *h : DIN 934 / ISO 4032

PATENTED: US20110173867

MAGAZINE

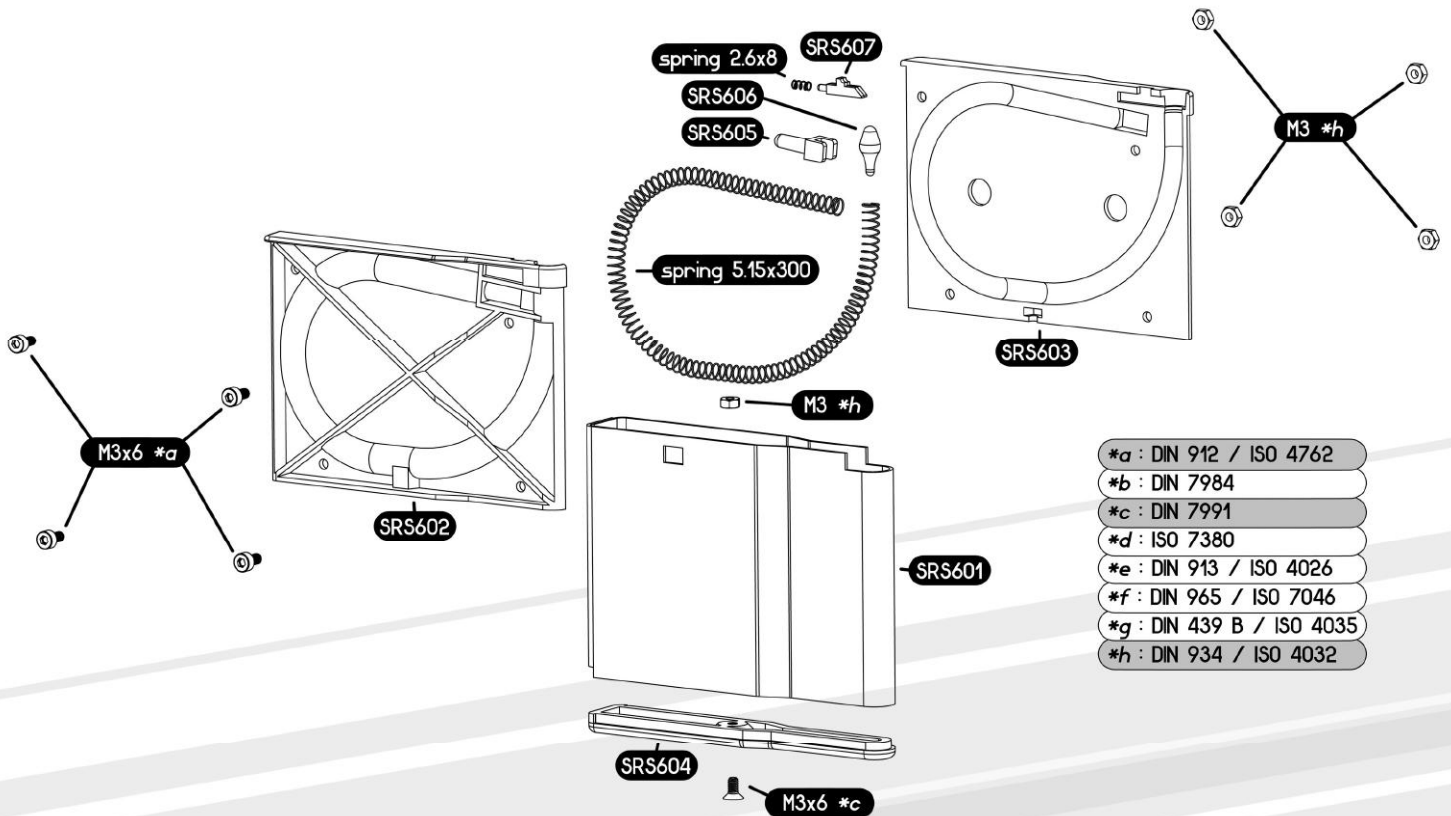

- *a : DIN 912 / ISO 4762
- *b : DIN 7984
- *c : DIN 7991
- *d : ISO 7380
- *e : DIN 913 / ISO 4026
- *f : DIN 965 / ISO 7046
- *g : DIN 439 B / ISO 4035
- *h : DIN 934 / ISO 4032



SERIAL NUMBERS

Serial number:
 Client code:

Color: black.....
 flat dark earth...
 olive drab.....

Type: 26"
 22"
 16" Covert

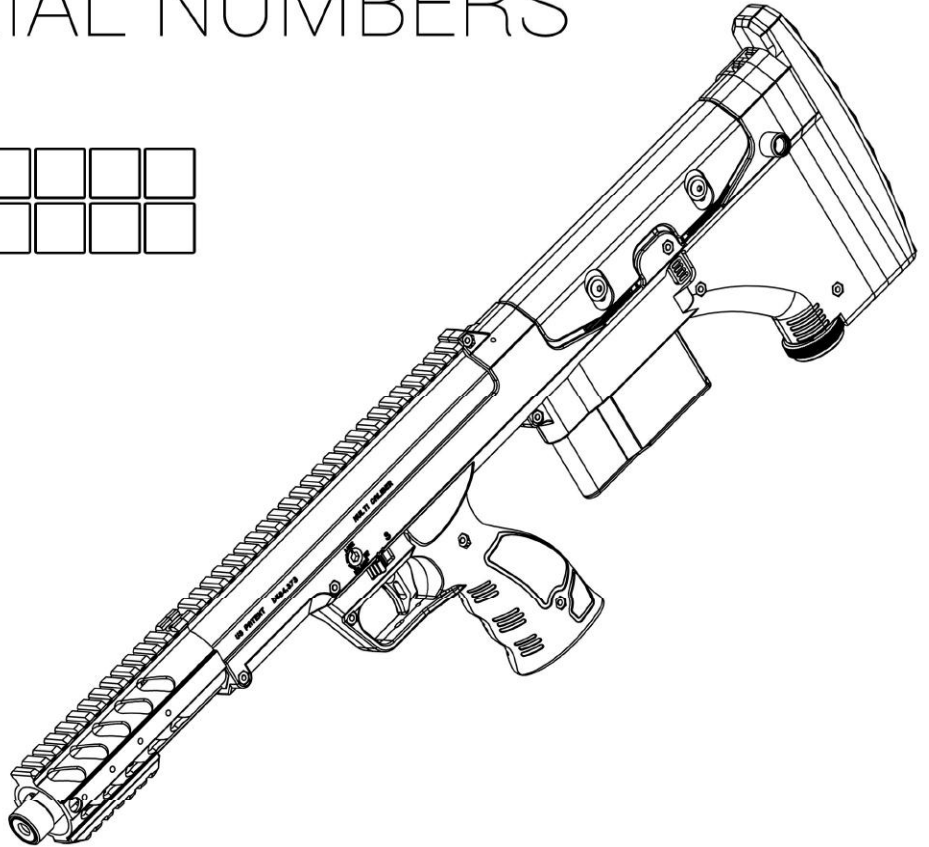

If you wish to contact us regarding your SRS-A1 or receive news about this product line, please contact us at info@silverback-airsoft.com with your serial number and client code as reference .

SPECIFICATIONS

MATERIALS

- aluminium 6061 T6:** receiver, outer barrels
- aluminium 6061 T5:** handguards
- aluminium 6061:** trigger box, piston, hopup body, threads protector, muzzle brakes, monopod
- 10.9 steel:** screws
- carbon steel:** piston sear, rod, cylinder assembly, QD sling clip, magcatch system, safety, magazine shell
- brass:** nozzle, bbs tube, inner barrels
- reinforced Nylon:** stock, buttplate spacers, cheekpad, additionnal rails, safety buttons
- bakelite:** bolt knob
- rubber:** piston head damper, buttplate
- 60° silicon:** hopup rubber

SIZE/WEIGHT

	Covert 16"	22"	26"
kerb weight	3.00 Kg	3.22 Kg	3.34 Kg
minimum length	675 mm	850 mm	980 mm

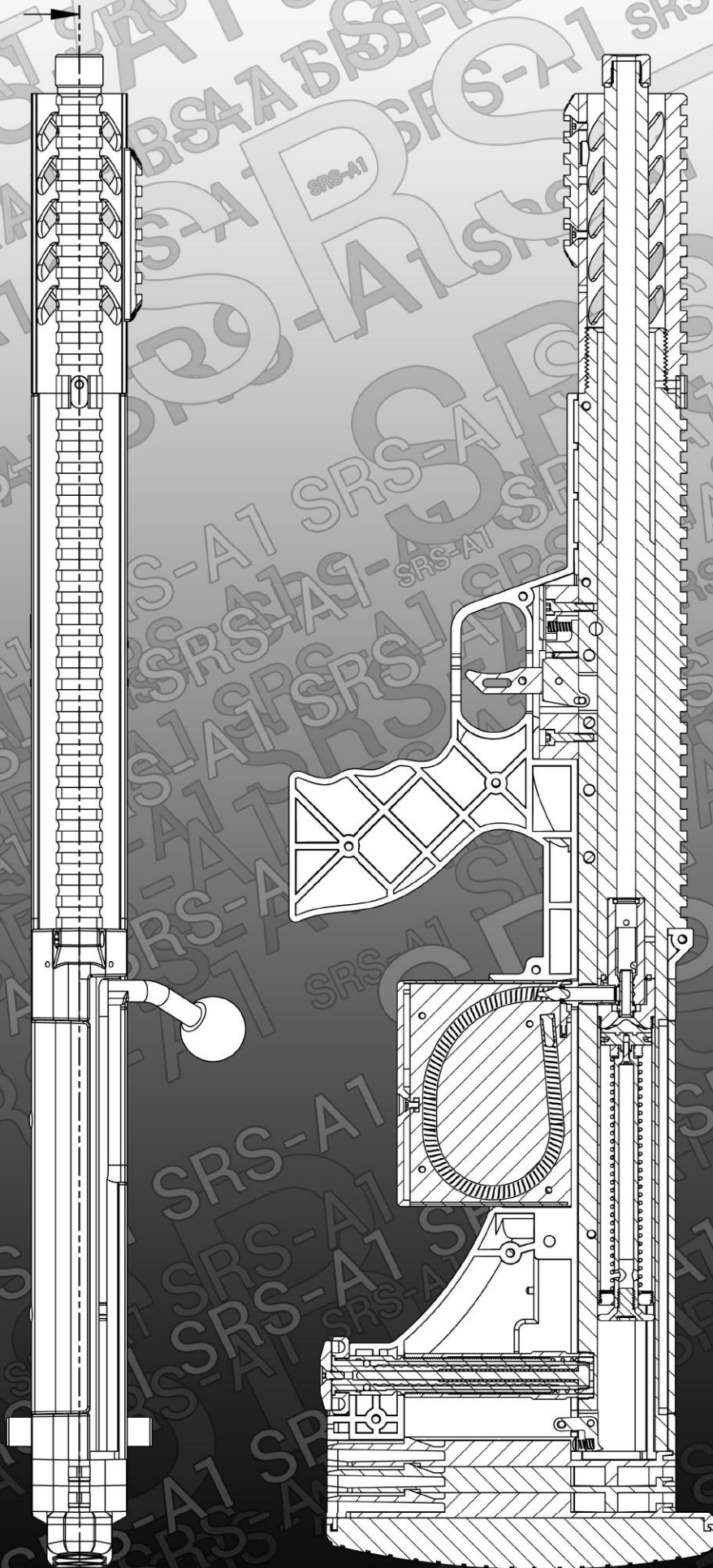

Made in Hong Kong



SILVERBACK AIRSOFT